



Online

Published by the Square and Folk Dance Federation of Washington



# Happy Thanksgiving

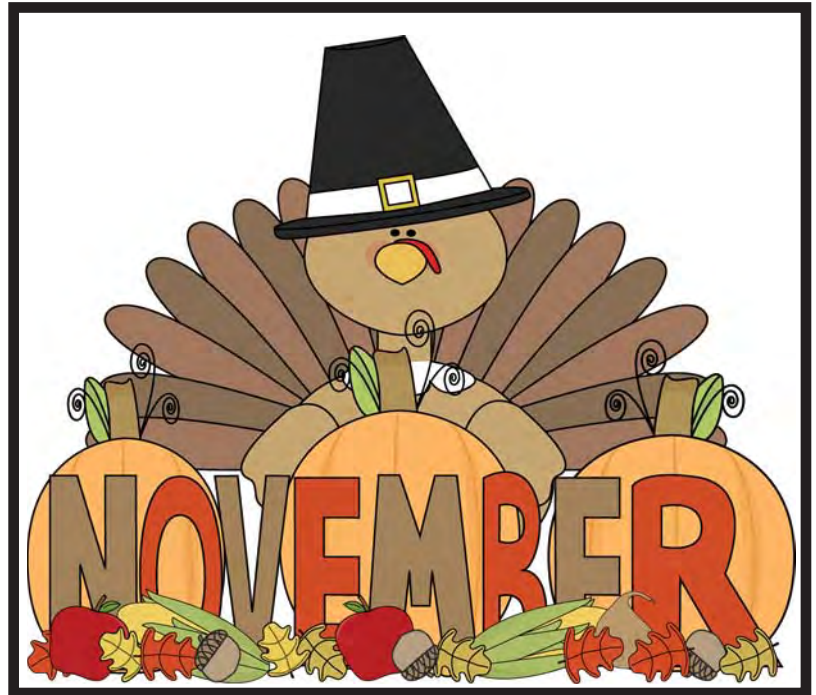

## CONTENTS

The Gavel.....	2
From Your Editor.....	3
Did You Know.....	4
Facebook report.....	5
Directory.....	8
Photo contest.....	9
The Winner Is?.....	10
Membership & Insurance.....	11
52nd Leadership Seminar.....	12
Craig's Caller Corner.....	16
Berka's Fishtailing 4 Rounds.....	17
Round of the Month.....	18
Sew Together.....	21
Solo Corner.....	23
Youth Coordinator & scholarship.....	23
Washington State Festival.....	27
70th National Convention.....	31
Heal-ium & In Memory of.....	48
Club News Begins.....	49
Blue Mountain Council.....	49
Central Area Council.....	51
Central Puget Sound Council.....	52
Evergreen Council.....	54
Federated Travel Club.....	55
Mount Baker Council.....	56
North Central Council.....	59
North Olympic Council.....	61
Peninsula Council.....	62
Rainier Council.....	64
Sou'Wester Council.....	67
Spokane Council.....	70

## STATE OFFICERS

Kay and Roger Mahan..... President  
 George and Sharon Broom.. Vice-President  
 Tom & Donna Rohde..... Treasurer  
 Darlene Jolly..... Recording Sec.  
 Holly & Paul Gonseth..... Corres. Sec.

## FOOTNOTES STAFF

Cynda Clark..... Editor/Publisher  
 Marsha Sullivan..... Business Manager  
 (NEED VOLUNTEER)..... Advertising Manager  
 Tina Allaway..... Education & Leadership Seminar  
 Craig Abercrombie..... Square Dance Editor  
 Bob & Linda Berka..... Round Dance Editor  
 Richard & Barbara Snyder..... Membership & Insurance  
 Karen & Dave Reichardt..... Sewing Editor  
 Marsha Sullivan..... Solo Corner  
 Sierra Weber..... Youth Coordinator



**THE GAVEL**  
**Kay and Roger Mahan**  
 206-612-1781  
[mahanrk@aol.com](mailto:mahanrk@aol.com)



The Federation meeting was held on October 10th via ZOOM. We had 43 households participating – what a great turnout! I hope that your representative was able to join to see what the Federation does.

If not this time, then you can join the next meeting in January – details TBD.

The 2021 State Festival plans are still on! Register NOW! If plans are cancelled, you can get your money back later.

We're all missing that personal connection to our dance friends. While we are staying in & staying safe, please try to reach out and check in with those friends.

We're all antsy to get back to dancing, but must remember to be mindful of our health & the safety of others.... and to Be Kind!

Kay & Roger Mahan



**The rates for FOOTNOTES online advertising are listed below:**

<u>Space size</u>	<u>Rate per issue</u>
<b>FULL PAGE:</b>	
7.5 x 9.75.....	\$25.00
<b>1/2 PAGE:</b>	
7.5 x 4.75 (horizontal).....	\$15.00
<b>1/4 PAGE*:</b> .....	
3.75 x 4.75 (vertical) or	
2.375 x 7.5 (horizontal) .....	\$10.00
<b>1/8 PAGE*:</b>	
2.125 x 2.375.....	\$ 5.00
<b>1 INCH*</b>	
1 x 7.5.....	\$ 3.00
Copy Change Monthly*** .....	\$ 2.00
Copy Change Permanent.....	No Charge

**AD DEADLINE: 10th of each month preceding the month of publication.**

Starting July1, Please make check out to FOOTNOTES. Mail to:

FOOTNOTES  
 % MARSHA SULLIVAN  
 2704 - 50th AVE NE  
 TACOMA, WA 98422

NOTE: \*\$2.00 Copy Change Monthly charge applies to all ads quarter page and smaller with the exception of one inch ads, which are

\$1.00 per month.....

Revised 8/2020

## A WORD FROM YOUR EDITOR

**Cynda & Larry Clark**

509-528-7081 Cell 509-585-2472 Home

[footnotes\\_wa@yahoo.com](mailto:footnotes_wa@yahoo.com)



TB (Tibbles),  
& Crazy Kramer.

Another month of no dancing!! One good thing about November...no more campaign ads, and we are one month closer to dancing. If we just knew when that might be!

Bowling has started so I get out of the house and away from the refrigerator. I bowl on 3 leagues (one with Larry and the other 2 are during the day with the Seniors.) I have been teaching a quilt class on line using Zoom. There were ladies from several different time zones, some were not familiar at all with Zoom. I've had a few struggles with it, being the host. I wish Lane had sent his Zoom article sooner.

Speaking of **Zoom Meetings**, if you aren't Zooming, Lane has some hints to get you going. Read his "**DID YOU KNOW**" article on the next page. It's a great way to connect with far away family & friends. Learn it now so you will be in the know over the Holidays when social distancing is still the norm.

Donna Rohde has asked her clubs to send in pictures of their pets. Great Idea! December's issue will host all our cute pets. Make sure your pet isn't left out! Plus you'll be entered in the drawing for the registration to the Spokane State Festival in 2022.

Wishing everyone a warm, safe, and healthy Thanksgiving Holiday.

*Cynda and Larry*

 *Cute pet pictures  
wanted for  
December's issue* 

**Send to your council reporter  
or send them to**

[footnotes\\_wa@yahoo.com](mailto:footnotes_wa@yahoo.com)

**Be sure to include your name  
and your pet's name**

FOOTNOTES DEADLINE(S)  
TENTH (10th) of the month  
proceeding publication.  
Send articles, ads and photos to:  
[footnotes\\_wa@yahoo.com](mailto:footnotes_wa@yahoo.com)

**AUGUST 1, 2020  
ADDRESS CHANGE FOR  
PAYMENTS TO FOOTNOTES**

**MARSHA SULLIVAN  
Z2704 - 50th AVE NE  
TACOMA, WA 98422**

# DID YOU KNOW?

by Lane Johnston

<https://www.wheresthedance.com>

[lanej@chessmenkastle.com](mailto:lanej@chessmenkastle.com)

<https://www.squaredance-wa-pics.org>



...there are a handful of Zoom hints and shortcuts that can make you look and feel like a “pro” with little very little extra effort on your part? Here are a few suggestions you might find useful:

First, establish a Zoom account (if you haven’t already done-so). It’s free. Download Zoom to your desktop PC, tablet, or smartphone.

When “joining a Zoom meeting”, run Zoom’s “TEST COMPUTER AUDIO” utility to make sure your microphone and speaker are functioning properly. It’s best if you do this BEFORE a meeting is scheduled to begin. Once you’ve checked to see that your audio is working, you’ll see a full list of SETTINGS.

In SETTINGS, click on the VIDEO icon and verify that your camera is also working properly. Adjust the room lighting so your face is well lit. Avoid sitting in front of window, especially during daylight hours. If you’re using a laptop, consider elevating it closer to shoulder or eye level by setting it on top of a box ...doing this will significantly enhance your on-screen “image”. [The ceiling is generally not a good backdrop, particularly if there’s a bright ceiling light behind your head.]

Now, for a few helpful keyboard shortcuts (there’s a full list under SETTINGS, but the “short list” list below will serve you well):

Use the keyboard’s PAGE UP and PAGE DOWN function whenever there are more participants in a meeting than will “fit” on a single screen.

Use “ALT+A” to either mute or unmute your microphone. If you are muted, you can Press and Hold the SPACEBAR to momentarily unmute yourself in order to ask a question or make a brief comment.

Use “ALT+V” to toggle your video “off” (unless you really want everyone on the Zoom meeting watch you eat that sandwich you didn’t have time to finish before the meeting started). Toggling your video “off” will enable you to eat that sandwich, run to the restroom, or blow your nose without being visible to everyone attending the meeting. When logged-in to your account, you can even upload a nice picture of yourself that will appear as a thumbnail instead of your video image whenever you toggle OFF using ALT+V. Use the same command to resume video mode.

One final suggestion:

Suppose you have a “report” to give during the meeting (State Federation Meetings, for example). Instead of “Sharing Your Screen” so everyone can read your report onscreen as you are reading it aloud (how boring is that?), consider using the “poor-man’s teleprompter” approach. Open up a digital copy of your report file on your desktop, then use the “ALT+TAB” function to toggle between your Zoom meeting screen and your report. With your video “ON”, the other participants in the meeting will still see YOU (not your report) as you present it, but you will be able to refer to your copy without having to look away from your computer screen! You can even scroll your report up as you present it so it will appear as though you are looking directly at the camera (and the other participants).

# FACEBOOK REPORT

BY  
LETRICIA HATCH  
letricia@hatch.net



Greetings!

Last month I joined a Facebook for Business webinar that discussed how the recent Facebook changes affect businesses. A golden nugget takeaway was that previously, an organic “reach” or post could reach up to only 20% of our subscribers, more if our subscribers shared our post. After the Facebook changes, that percentage went down to only 2%. There are two remedies to combat the minimized reach:

- 1) encourage every subscriber to add our page to their “Favorites”. This will make them more likely to see our posts. They need to click on the three dots next to the “Like” button, go to “Follow Settings”, click “Favorites” and then “Update”. (See diagrams)

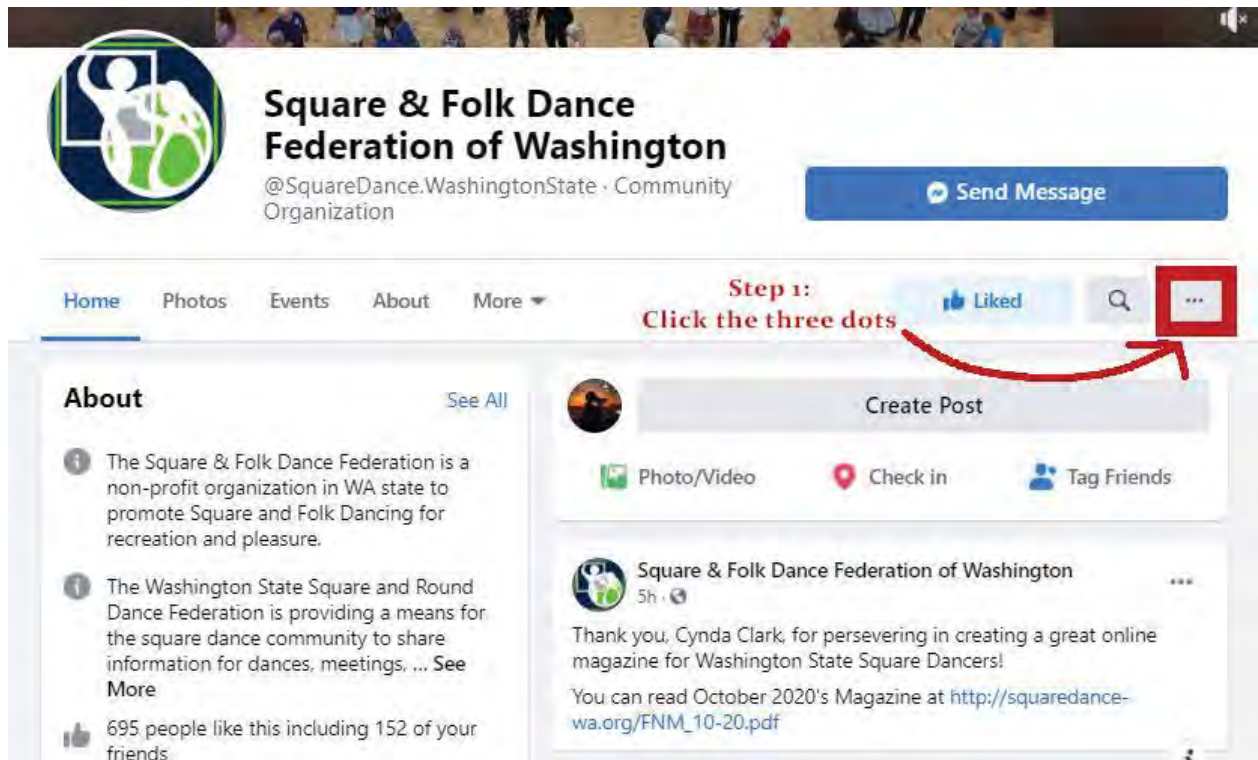



# Square & Folk Dance Federation of Washington

@SquareDance.WashingtonState · Community Organization

Send Message

Home Photos Events About More

Step 2: Click Follow Settings

Liked

Search

## About

See All

- The Square & Folk Dance Federation is a non-profit organization in WA state to promote Square and Folk Dancing for recreation and pleasure.
- The Washington State Square and Round Dance Federation is providing a means for the square dance community to share information for dances, meetings, ... See More
- 695 people like this including 152 of your friends



Create Post



Photo/Video



Check in



Square & Folk Dance Federation of Washington · 5h ·

Thank you, Cynda Clark, for persevering in c magazine for Washington State Square Dan wa.org/FNM\_10-20.pdf

SQUAREDANCE-WA.ORG

Follow Settings

Save

Share

Like As Your Page

Unlike As Your Page

Invite Friends

Block Page

Step 3: Click Favorites



Home Photos

## About

- The Square & Folk Dance Federation is a non-profit organization in WA state to promote Square and Folk Dancing for recreation and pleasure.
- The Washington State Square and Round Dance Federation is providing a means for the square dance community to share information for dances, meetings, ... See More
- 695 people like this including 152 of your friends
- 725 people follow this page

### Follow Settings

#### News Feed

Choose how you'll see Posts from this Page in your News Feed.

#### Favorites

You'll see posts higher in your News Feed.

#### Default

See posts in their usual order from this page.

#### Snooze

Stop seeing this Page's posts for 30 days.

#### Off

Never see posts from this Page in your News Feed.

#### Notifications

Choose what types of posts you want to be notified about.



#### Posts

Highlights



#### Video

Highlights



#### Live Video

Highlights



#### Offers

All limited-time discounts and promos.

#### Unfollow this Page

Stop receiving all updates from this Page.

Step 4 Update

Cancel

Update

We can also

2) collect email addresses. What I learned was that maintaining your own email list is the only sure-fire way of reaching your desired audience. Twitter, Instagram and Facebook can cancel your account or any part thereof at any time and you have no way of retrieving or rebuilding the audience you created and lost. Your email list is one of the most important marketing and outreach tools that a business or organization can have.

That's it for me, thank you for your time.

Letricia Hatch



Find us on:  
**facebook®**

Directory On Sale...Order yours today!

\$5.00 + 2.00 shipping

Holly Gonseth

[squaredancehollyg@gmail.com](mailto:squaredancehollyg@gmail.com)

# 2020 - 2021

## State Directory

Published by

The Square and Folk Dance Federation of Washington



Washington State  
Square Dance Festival

June 17-19, 2021

Delta Marriott Hotel  
Everett, WA

<https://festival.wasdf.org/>

<https://www.festival.wasdf.org/>



# SEND IN A PHOTO AND WIN

One of my goals, when I took over Footnotes, was to increase the viewing of our Magazine. I've put some thought into this and would like to GIVE BACK to the dancers who read our magazine.

Covid has caused us all to miss our dancing friends so I'm asking for **Photos** of dancing/dancers, interesting places you've been, animals in the wild or backyard, or something interesting of your choice. I've been using photos from the internet but your photos are far more interesting. They will be placed through out Footnotes this year and may not be with your club or council. 1-2 photos per month will get you into the drawing for the 50.00 registration to 2022 festival in Spokane.

So I know who to give credit to, please rename your photo with your name and if more than one photo your name and a number. *EXAMPLE: Cynda Clark 2.jpg*

*Please limit the number of photos to 2 per month*

Winner will be announced at the 2021 State Festival. in Everett, WA.

After the winner registers for the 2022 festival to be held in Spokane, Footnotes will reimburse the registration fee up to \$50.00.

GOOD LUCK!

[wasquaredance@yahoo.com](mailto:wasquaredance@yahoo.com)



DUE TO COVID THE 1/2 PAGE WINNER FOR ADVERTISERS IS SUSPENDED until dancing resumes (January?)

FOR CLUBS, COUNCILS,  
CALLERS, CUERS &  
COMMERCIAL ADVERTISERS

Clubs and Councils, Callers and Cuers, and Commercial advertisers, you are the main financial supporters of the Footnotes Magazine. To thank you for your past, present and future support, Footnotes Magazine will award a ½ page ad, or a 15.00 credit to an advertiser in the current issue. 1 winner will be chosen, every month, starting with the January issue.

This will be a random drawing and winners may win no more than 2 times in any one volume year. (January-June)





## MEMBERSHIP & INSURANCE

Richard & Barbara Snyder

5612 S. Napa Street • Spokane, WA 99223-8248

509.443.0126

[richlsnyder@gmail.com](mailto:richlsnyder@gmail.com)



We will soon be emailing up-dated club membership information to each council treasurer. We are asking each council to distribute them accordingly. Also, the audit is being completed and will be mailed out to the clubs involved. Please take care of this information when you receive it.

As you may notice, our picture has changed. Sadly, we have lost our two beagles. We have been working for nearly a year to find a replacement (we want a beagle). We noticed that our neighbor was walking a brand-new beagle. She informed us she had gotten her beagle from a breeder in Moses Lake (after a year's research). We contacted this breeder and were put on a waiting list two litters out (almost a year). That all came to a climax on October 3rd when we became the proud parents of a brand-new female beagle puppy named Shelle (pronounced Shelley). Almost

a week has gone by now and we are still operating on a schedule of two hours on and two hours off, 24 hours a day. Last night we did get a five hour stretch of continuous sleep. We have been so lucky to have had such beautiful weather which allowed us to spend daylight hours outside and the little girl absolutely loves to be outside. It did take us a couple of days to puppy proof the yard. We had forgotten how many things a little one can get into. We love her very much and it is certainly helping us to get through these pandemic times.

*Take care,  
Richard and Barbara Snyder*



# 52<sup>ND</sup> ANNUAL EDUCATION & LEADERSHIP SEMINAR TINA ALLAWAY

PUBLICITY AND PROMOTIONS  
[tina.allaway@gmail.com](mailto:tina.allaway@gmail.com)



Happy Thanksgiving everyone. Hoping all of you are taking care of yourselves and staying well. There is a lot happening as we look to the future. Safely reopening square dance activities and introducing new people to this wonderful activity of ours. New classes, workshops, weekend dances, special spring time dance weekends and spending our summer dancing to the wonderful guest callers at the Circle 8 Ranch near Cle Elum

We on the Leadership committee would like to invite every square dancer in the Pacific Northwest to come and experience the terrific things that the Leadership/Education weekend has to offer. Caller and Keynote Speaker Ken Rituchi, Chairman of the Executive Committee of Caller Lab. He will conduct a square dance workshop Saturday afternoon. He is the featured caller for Saturday night then on Sunday he will be the keynote speaker sharing some of his square dance wisdom with us. Since we missed in 2020 we will have Bob & Linda Burka back in 2021 to do the round dance workshop and be the featured callers for Saturday night dance.

Friday night will be a welcome dance that will feature callers and callers from all over the state of Washington. Saturday morning starts off early with some cinnamon rolls and coffee in the main hall. Then get ready for a day of learning new ideas and sharing some of yours. Topics will be, How To Promote Your Club For Free, Lane Johnson presenting. Social Media Strategies For Square Dance Clubs, Letricia Hatch presenting. Promote Safety-dancers and Facilities and Still have Fun, Paul Gonseth presenting. Then again sharing her secrets for sewing beautiful things Karen Reichardt will be working her magic in the sewing shed.

You will meet new friends and enjoy the ones you already know. Learning ideas that might help your club and share the ideas that are working for your club. Come ask the questions and find the answers. Come dance and relax in the campground. I promise you will be glad you did.

Positive thoughts for the year ahead, to get back to our friends and the dance floor.

Stay healthy and we will see you soon,

*Tina Allaway*



# Start planning now for the 52nd Annual Education and Leadership Seminar July, 10-11 2021 WITH:



KEN RITUCCI



BOB & LINDA  
BERKA



## Registration Information

Bruce and Judy Ottoson  
2203 W Monroe Rd  
Spokane, WA 99208

[bruceottoson@msn.com](mailto:bruceottoson@msn.com)



Smokey Sun in Spokane  
Photo By Priscilla Davis

The Square and Folk Dance Federation of Washington's

# 52ND

## EDUCATION & LEADERSHIP SEMINAR

at the beautiful Circle 8 Square Dance Ranch near Cle Elum, WA

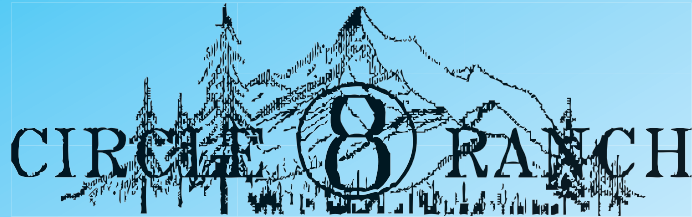

**KEN RITUCCI**  
Caller/Keynote Speaker  
West Springfield, MA



**BOB (LINDA) BERKA**  
Cuer/State Round Dance Coordinator  
Oak Harbor, WA



### July 9, 10 & 11, 2021

#### Registration Information

Bruce & Judy Ottoson  
2203 W. Monroe Rd.  
Spokane, WA 99208-9744  
509.475.3620  
bruceottoson@msn.com

[www.squaredance-wa.org](http://www.squaredance-wa.org)

LEADERSHIP REGISTRATION

COMING SOON

THERE IS

*always, always,*

ALWAYS

something

*to be thankful for*



## **CRAIG'S CALLER CORNER**

**CRAIG ABERCROMBIE**  
[Craigabercrombie14@gmail.com](mailto:Craigabercrombie14@gmail.com)

**F**all weather brings gorgeous colors means leaves to rake and pine needles to cleanout of rain gutters, unless you are in one the areas that have experienced these terrible wild fires, prayers for all of you to help you rebuild.

With no dancing, are you keeping in touch of our (your) dancers? We are seeing various means of zoom meetings, emails, Facebook, Twitter, Instagram and others. I usually send out a newsletter with my calendar to my dancers. But, without a calendar, I still have sent an email out as we tell each other what closets we have cleaned out or a project completed that we would have never done when we were dancing. Some have even sent me pictures of which projects, gardens, flowers and whet else they have been doing.

This is a good time to brainstorm and prepare how to invites new students to classes once we begin again. You may want to do demos to get our activity out in the publics eye. We need to get out and put on a SHOW and

have FUN! Do you now how many people do not even know about square dancing? Callers try to utilize upbeat recognizable music. Dancers dress for success. Variety of attire is best. Traditional dress mixed with modern and casual. Newer or less active dancers can assist in other ways like passing out cards or brochures. Happy Thanksgiving to you all. We have so much to be thankful for. Also Thank you to all you Veterans and for your service to our country.

*For a Great Month,  
Craig*







## FISHTAILING FOR ROUNDS

Bob and Linda Berka

[berkarl@whidby.net](mailto:berkarl@whidby.net)

*Respectfully,  
Bob and Linda Berka*

Talking about “STYLING” this month.

We feel that styling is an individual emotional preference in movement and like personality, it belongs to you. Each couple has their own expression as to what is a natural feeling for a particular rhythm of music. No one can tell you how you feel, no publication or book can give you this thing called “Styling”.

We, the separate individuals of the “Bob and Linda team”, like to feel the mood of the music. Learning a dance from the cue sheet is like putting a puzzle together. Exploring the directions, trying to create what the choreographer had in mind when writing the dance. Dancing the dance, we begin transferring to the other partner, our separate feelings of both the music mood and the technique in which the dance was written—to finalize, and create our own “Bob and Linda” style of the dance. We attempt to blend every step and make every movement appear to be as smooth and comfortable as possible. We try to keep in mind that along with smoothness and continuity, attitude plays a major role in dance. If you are smiling, dancing smoothly and have the appearance of an enjoyable experience, you can make the most simple routine look interesting and pleasant. Round Dancing should not have the rigid “drill-team” look, but should appear to be a free and easy experience; one that is moving smoothly and with grace. Each couple should demonstrate their own physical and emotional characteristic of good styling.

Little things can make a big difference in your dance style. Don’t “over-style” – to over-do could look tacky. Better too little, than too much. Too much arm, leg, hip, skirt, etc., action is out of place! Listen and attempt to follow suggestions made by your instructors. Watch other dancers and if you see them demonstrate something you like, try executing the same style – it may please you greatly and what a reward! Take into consideration the different body structures; such as tall or short, ect. Consider too, that just because it looks nice when someone else does a movement, does not mean it will look nice when you do it. It may not be your style at all. Keep watching, you may find another style that fits you and your “personal touch”.....maybe you will discover a style that you and

your partner can express with even more gracefulness than dancers you have been observing.

Styling is not to be confused with technique! There are many steps and figures that are designed to be done with certain and precise footwork. These are constructed to make the couple turns compact and the dancers will end in the proper partner position. Styling? No! They are the manner in which the movement is to be executed to maintain the proper position and not force one of the partners to travel a greater distance.

There are many general rules of styling to practice. A lovely beginning is to SMILE! The entire presentation is spoiled by a “sour face”. Certainly, do not stare at your partner with a “fixed – fake” grin on your face. Compliment your partner by smiling at each other occasionally during the dance. Let the other know that you enjoy dancing with them. Many couples do not have fancy styling as they dance, however they express their pleasure and enjoyment by looking happy and it is a pleasure to watch them. Dancers that are expert dancers and know all the latest routines, along with many extra styling maneuvers, yet do not look like they are enjoying themselves are really not pleasureable to observe at all. Remember to be happy and “Smile”! That alone can be contagious!

Rounds For You...what an art this dance recreation is of ours. We would like to pass on to you a paragraph found in a very old book written by Lloyd Shaw....it really “moved” both of us....it reads as follows:

I love to see a young couple who love to dance – lithe, eager, erect; the give and take of their light and delicate hold; the exquisite teamwork in the dip and sway and whirl of their bodies! With their weight properly forward they move as lightly, as gossamer. Oh, the bewitching line from erect body through curving thigh as she reaches lightly to a backward step, the graceful whirling of her skirt; the light touch of his protective strength as he whirls her about him. It is beauty at its best. Beauty to behold, but even more beauty to be partner to.

Thank you for reading this article originally written by us years ago in Footnotes Magazine. We will continue this article suggesting some factors we feel necessary to help you blend to better styling.

# NOVEMBER'S ROUND OF THE MONTH

## I Did it My Way

CHOREO: Shawn and Wendy Cavness, 34403 56<sup>th</sup> Ave So., Auburn, WA 98001  
(253) 929-8161 [shawn@rounddancing.org](mailto:shawn@rounddancing.org) [www.rounddancing.org](http://www.rounddancing.org)

RECORD: Song Name: I Did It My Way (Waltz) Artist: Tony Evans and His Orchestra  
CD: The Ultimate Waltz Collection Time: 3:07 as Downloaded  
Download from casa-musica-shop.de Music Modifications: Speed up 7%

FOOTWORK: Woman Opposite unless noted (Women's footwork in Parentheses)

RHYTHM: Waltz Phase 2 DIFFICULTY: Average

SEQUENCE: Intro, A, B, C, A, C, End Released: October 12, 2019

### Intro

#### 1-4 Wait 2 Measures ; ; Dip Back ; Recover and Touch ;

(1-2) CP WALL - wait ; ;

(3-4) bk L (fwd R) with knee flexed leaving R fwd (bk L) , - , - ; rec fwd R , tch L , - to CP WALL ;

### Part A

#### 1-4 Left Turning Box ; ; ; ;

(1-2) fwd L commencing 1/4 LF trn , comp trn sd R to fc LOD , cl L ; bk R commencing 1/4 LF trn , comp trn sd L to fc COH , cl R ;

(3-4) fwd L commencing 1/4 LF trn , comp trn sd R to fc RLOD , cl L ; bk R commencing 1/4 LF trn , comp trn sd L to CP fc WALL , cl R ;

#### 5-8 Dip Back ; Maneuver to CP RLOD ; Two Right Turns to BFLY WALL ;

(5-6) bk L (fwd R) with knee flexed leaving R fwd (bk L) , - , - ; fwd R beg RF upr bdy trn , cont RF trn sd L , cl R (bk L beg RF upr bdy trn , sd R , cl L) to CP RLOD ;

(7-8) bk L comm trn up to 1/4 RF , sd R cont RF trn up to 1/4 , cl L ; fwd R comm trn up to 1/4 RF , sd L cont RF trn up to 1/4 to BFLY WALL , cl R ;

#### 9-12 Balance Left ; Reverse Twirl ; Through Twinkle ; Through Face Close ;

(9-10) sd L, XRib rising on toe, rec L ; fwd R , fwd L , sd R (sd and fwd L trn 1/2 LF under jnd hands , sd and bk R trn 1/2 LF , sd L) ;

(11-12) thru L twd RLOD , sd R trn LF to OP LOD , cl L ; thru R twd LOD , fwd and sd L trng twd ptr to CP WALL , cl R ;

#### 13-16 Dip Back ; Recover and Touch ; Twirl Vine ; Through Face Close ;

(13-14) bk L (fwd R) with knee flexed leaving R fwd (bk L) , - , - ; rec fwd R , tch L , - to CP WALL ;

(15-16) sd L , XRib , sd L (sd and fwd R turning 1/2 RF under jnd hnds , sd and bk L turning 1/2 RF , sd R) to BFLY WALL ; thru R twd LOD , fwd and sd L trng twd ptr to CP WALL , cl R ;

## Part B

### **1-4 Waltz Away ; Wrap the Lady ; Forward Waltz ; Roll the Lady Across ;**

- (1-2) releasing lead hands and retaining trail hands and turning away from partner fwd L , sd and fwd R , cl L ; fwd R leading ptr to trn LF , fwd L (cont LF trn) , cl R to wrapped pos LOD ;  
(3-4) fwd L , fwd R , cl L ; fwd R releasing trail hnds lead ptr to roll across in front of M twd COH , fwd L , cl R (fwd L rolling across in front of ptr , sd and bk R cont roll , cl L ) to LOP LOD ;

### **5-8 Open Box ; ; Through Twinkle ; Through Face Close ;**

- (5-6) fwd L , sd R , cl L (fwd R , sd L , cl R) ; bk R , sd L , cl R (bk L , sd R , cl L) ;  
(7-8) thru L twd LOD , sd R trn LF to OP RLOD , cl L ; thru R twd RLOD , fwd and sd L trng twd ptr to CP COH , cl R ;

### **9-12 Lace Across ; Waltz Together to BFLY WALL ; Balance Left and Right ; ;**

- (9-10) passing bhd W with ld hands jnd moving diagonally across line of progression fwd L , fwd R , cl L to LOP RLOD ; fwd R , fwd L , cl R to BFLY WALL ;  
(11-12) sd L , XRib rising on toe , rec L ; sd R , XLib rising on toe , rec R ;

### **13-16 Step Swing ; Lady Spin to LOP RLOD ; Through Twinkle ; Through Face Close to BFLY WALL ;**

- (13-14) sd and fwd L to OP LOD , swing R thru , - (sd and fwd R to OP LOD , swing L thru , - ) ; in plc R , L , R turning RF to fc RLOD (LF spin 1 1/2 on L , R , L end fcg RLOD) to LOP RLOD ;  
(15-16) thru L twd RLOD , sd R trn LF to OP LOD , cl L ; thru R twd LOD , fwd and sd L trng twd ptr to CP WALL , cl R ;

## Part C

### **1-4 Waltz Away and Together ; ; Solo Turn to BFLY WALL ; ;**

- (1-2) releasing lead hands and retaining trail hands and turning away from partner fwd L , sd and fwd R , cl L ; sd and fwd R turning to face partner , sd and fwd L , cl R ;  
(3-4) fwd L comm LF trn away from ptr , cont trn sd R , cl L to comp 3/4 trn (fwd R comm RF trn away frm ptr , cont trn sd L cl R to comp 3/4 trn) ; bk R comm LF trn , cont trn sd L , cl R (bk L comm RF trn , cont trn sd R , cl L ) to BFLY WALL ;

### **5-8 Step Swing ; Spin Maneuver ; Two Right Turns to CP LOD ; ;**

- (5-6) sd and fwd L to OP LOD , swing R thru , - (sd and fwd R to OP LOD , swing L thru , - ) ; fwd R trng RF in frnt of ptr , sd L , cl R to CP RLOD (LF spin on L , R , L end fcg LOD) ;  
(7-8) bk L comm trn up to 1/4 RF , sd R cont RF trn up to 1/4 , cl L ; fwd R comm trn up to 1/4 RF , sd L con RF trn up to 1/4 to CP LOD , cl R ;

### **9-12 Forward Waltz ; Drift Apart ; Through Twinkle Twice to SCAR LOD ; ;**

- (9-10) fwd L , fwd and slightly sd R , cl L ; sip R , L , R (drift apt L , R , L ) to LOP WALL ;  
(11-12) thru L twd WALL , sd R trn LF to OP COH , cl L ; thru R twd COH , sd L trn RF to SCAR LOD , cl R ;

### **13-16 Progressive Twinkle 3X ; ; ; Forward Face Close to CP WALL ;**

- (13-14) fwd L , sd R trng slight LF , cl L to BJO ; fwd R , sd L trng slight RF , cl R to SCAR ;  
(15-16) fwd L , sd R trng slightly LF , cl L to BJO ; fwd R , sd L to fc , cl R to CP WALL ;

## End

### **1-3 Box ; ; Dip Back and Kiss ;**

- (1-2) fwd L , sd R , cl L ; bk R , sd L , cl R ;  
(3) bk L (fwd R) with knee flexed leaving R fwd (bk L) , - , - ;

## I Did it My Way (Head Cues)

Waltz Phase 2

Intro (4) CP WALL – Wait 2 Measures;; Dip Back; Recover and Touch;

A (16) Left Turning Box;;; Dip Back; Maneuver; Two Right Turns to BFLY WALL;; Balance Left; Reverse Twirl; Through Twinkle; Through Face Close; Dip Back; Recover and Touch; Twirl Vine; Through Face Close;

B (16) Waltz Away; Wrap the Lady; Forward Waltz; Roll the Lady Across; Open Box;; Through Twinkle; Through Face Close to BFLY WALL; Lace Across; Waltz Together to BFLY WALL; Balance Left and Right;; Step Swing; Lady Spin to LOP RLOD; Through Twinkle; Through Face Close to BFLY WALL;

C (16) Waltz Away and Together;; Solo Turn to BFLY WALL;; Step Swing; Spin Maneuver; Two Right Turns to CP LOD;; Forward Waltz; Drift Apart; Through Twinkle Twice to SCAR LOD;; Three Progressive Twinkles;;; Forward Face Close to CP WALL;

A (16) Left Turning Box;;; Dip Back; Maneuver; Two Right Turns to BFLY WALL;; Balance Left; Reverse Twirl; Through Twinkle; Through Face Close; Dip Back; Recover and Touch; Twirl Vine; Through Face Close;

C (16) Waltz Away and Together;; Solo Turn to BFLY WALL;; Step Swing; Spin Maneuver; Two Right Turns to CP LOD;; Forward Waltz; Drift Apart; Through Twinkle Twice to SCAR LOD;; Three Progressive Twinkles;;; Forward Face Close to CP WALL;

End (3) Box;; Dip Back and Kiss;





**SEW MUCH FUN**  
Karen & Dave Reichardt  
[dkreichardt@gmail.com](mailto:dkreichardt@gmail.com)  
[www.squaredancesewing.com](http://www.squaredancesewing.com)



## Blindhem Foot

This is a foot that most people have but never learn to use. Tailors use this stitch. It looks professional, doesn't pucker and does not come out like a hand sewn hem. As with all other techniques, it takes a little practice. Take a couple of scraps and try this foot.

1. Finish the edge of the hem. My favorite finish is the triple zig zag "D" on the widest setting. This stitch does not cause the edge to bunch up like the regular zig zag can. This edge can also be serged or any other stitch of your choice.
2. Fold the hem up the desired amount. Glass headed pins allow the hem to be pressed at this point. Pressing will ease back any stretch that has occurred along the finished edge.
3. Set the machine on the longest straight stitch "B", for basting. Sew all around the hem one half inch from the finished edge of the hem. Use a contrasting thread so that it can be easily pulled out later.
4. Position the garment, hem down and fold the garment back to the straight stitching, making sure the hem edge protrudes one half inch. This will be the inside of the garment.
5. Position the fabric so the red edge guide runs along the fold. The blind hem foot for your machine may look different, like the white guide one. While sewing keep the fabric fold tight against the guide.
6. Set the machine on the hem stitch "F".

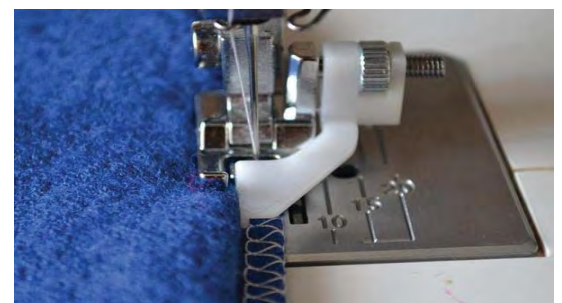
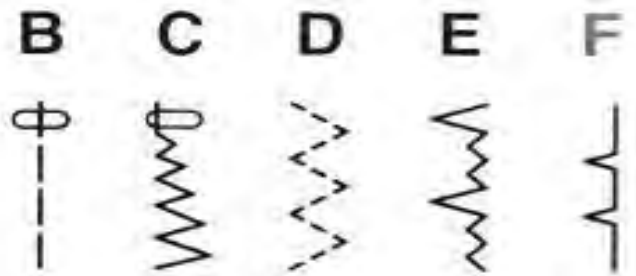

This is where the practice is necessary. The needle will take three straight stitches and then zig over to the left. That zig should just barely catch the fold. Use the stitch length, width control and the position of the guide to adjust the stitch.

Check the front of the garment to see what the stitch looks like. If the stitch punctures are very visible on the front, try moving the edge guide to the left, with the knurled adjusting knob. Just a little adjustment and try again.

Thinner fabrics need a very tiny bite. Thicker fabrics need a bigger bite. When the hem is complete, pull out the basting stitching and press again.

The advantages of using the blind hem foot on the machine verses hand hemming are;

1. Faster - Once the stitch is set correctly, you can speed down the hem.
2. Reduce puckering - Hand stitches tend to pucker because most stitchers draw the thread too tight. If there is puckering with the blind hem foot, reduce the upper thread tension a little and increase the stitch length.
3. Stronger hem - If one part of the hem stitching is broken, the hem won't completely pull out like it can with hand stitching.
4. More flexible - The little zigs add stretch to the stitching so it is less likely to pop than hand stitching. The other blind hem stitch "E" is designed to be used on very stretchy fabrics.

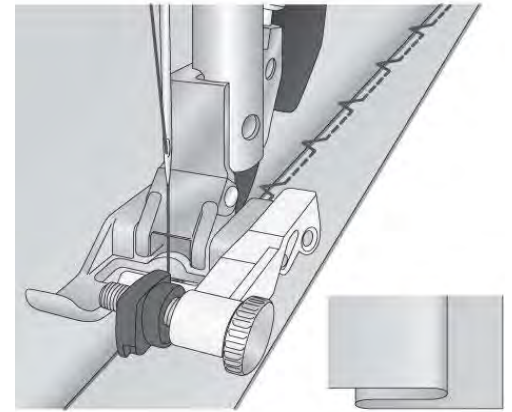

While working at a sewing machine shop, my job was to teach all of the different feet and accessories for the machines. It really opened my eyes to the idea of the right tool for the job. Making my stitching more accurate, faster and more creative was the result.





## SOLO CORNER

Marsha Sullivan

[solo@dosido2go.com](mailto:solo@dosido2go.com)



### SOLO CORNER

November 2020

By Marsha Sullivan

Last month I sat in on the 2021 State Festival monthly meeting, hosted by Mount Baker Council. The message is, "Register! Please!" It isn't so long ago that I was part of the Rainier Rendezvous registration team, and that was also our mantra. But this year is different. This year there are no dances to remind us, no flyers for us to take home... and if you're like me, you're probably not thinking too much about dancing next summer, because we've already been eight months without it.

For these very reasons, the committee needs your support. If you are waiting to see if the ban on dancing will be lifted first, please reconsider. The committee needs seed money to develop their programs. They also need an idea of how many people to plan for. It doesn't matter whether there are 150 people registered or 850, the dance will go on (unless the State mandates that we cannot). I encourage you to go to [www\\festival.wasdf.org](http://www.festival.wasdf.org) and support our fun activities. When you are done registering, take a look at the merchandise, place your food orders, and make your hotel reservation. There is absolutely no risk. If the State mandates that we cannot meet as a dance group, you will receive a total refund of your registration, meals, and hotel reservation.

At our last state festival, there were over 300 registered solos. The chances of finding someone to dance with are pretty darn high.

Meanwhile,

If you can start this day without caffeine,

If you can always be cheerful, ignoring aches and pains,

If you can resist complaining and boring people with your troubles,

If you can eat the same food every day and be grateful for it,

If you can understand when your loved ones are too busy to give you any time,

If you can take criticism and blame without resentment,

If you can relax without alcohol, and

If you can sleep without the aid of drugs,

Then you are probably the family dog!





## YOUTH COORDINATOR

**Sierra Weber**

[P.Dolphin1110@comcast.net](mailto:P.Dolphin1110@comcast.net)

253-445-6692

**H**appy November everyone!  
I cannot believe it is already November.

I want to give a special thank you to anyone and everyone who has donated in any way to the youth fund. The money awarded to the youth in April is all by donation. Any amount is greatly appreciated. Plus, the money is going to wonderful and well deserving young men and women. If you ever want to donate to this amazing scholarship then you can contact Tom Rohde:

Tom Rohde  
Washington State Federation Treasurer  
31429 114th Pl. SE  
Auburn, WA 98092  
Attn: Youth Scholarship

Or if you are or someone you know is 16 to 22 years of age and pursuing a postsecondary education next year then this is the perfect scholarship for them! Contact me with any questions:

Youth Scholarship:  
c/o Sierra Weber  
1717 Wildflower CT SE  
Puyallup, WA. 98374

Or email: [P.Dolphin1110@comcast.net](mailto:P.Dolphin1110@comcast.net)  
I hope you are all staying safe and making memories.

*See you all soon,  
Sierra Weber*

# November

## YOUTH SCHOLARSHIP....



**P**lease consider giving a donation to the Youth Scholarship. The scholarship is given to students who are actively involved in square dancing and the funds must be used to further their education beyond high school.

**Please send donations to:**

Tom Rohde  
Washington State Federation Treasurer  
31429 114th Pl. SE  
Auburn, WA 98092

**Attn:**  
Youth Scholarship



**Square and Folk Dance  
Federation of Washington, Inc.**

**Youth Scholarship Fund**

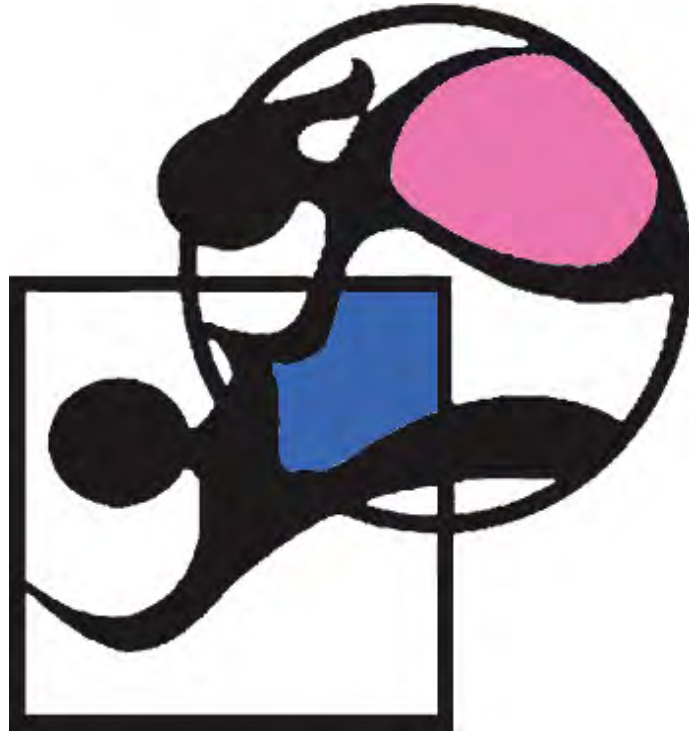

On January 15, 2000, the Square and Folk Dance Federation of Washington, Inc. voted to award an annual Youth Scholarship. Scholarships are awarded at the Washington State Square and Folk Dance Festival in June of each year. Monies are paid directly to the winner's college or trade school.

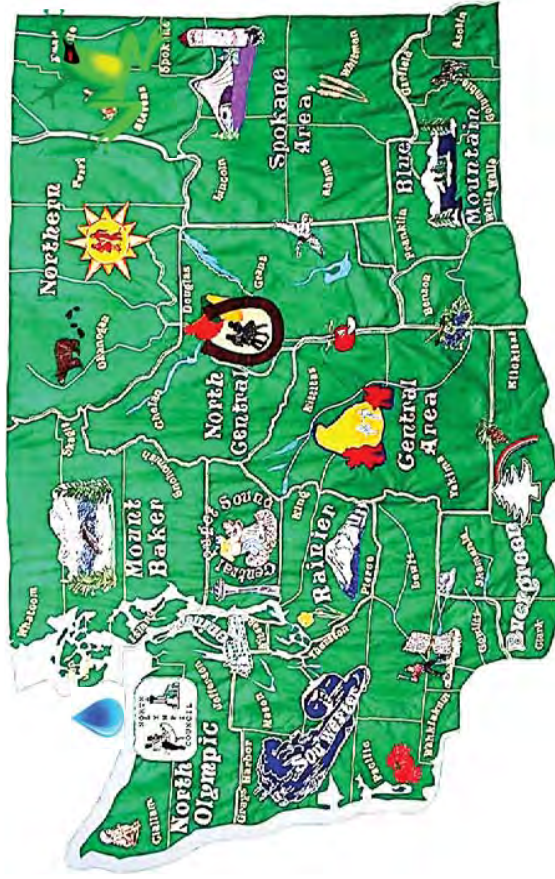

Tax deductible donations to this scholarship may be made through the Square and Folk Dance Federation of Washington, Inc. State Treasurer.

**Supporting our Leaders  
Of Tomorrow!**

For more information to to:  
[www.squaredance-wa.org](http://www.squaredance-wa.org)

Square and Folk Dance Federation of Washington, Inc.

## Square and Folk Dance Federation of Washington, Inc.

The Square and Folk Dance Federation of Washington, Inc. is accepting applications for the merit based \$1,000.00 scholarship from youth members active within our clubs and councils.

### Eligibility Requirements

- Applicants must be active members in good standing of a Washington State Federated Club.
- Applicants must be 17 through 22 years of age.
- Applicants must show a commitment to the promotion of square dancing.
- Funds must be used to further education beyond high school.

### Application Procedures

The following items are required:

- A completed application form
- A letter of nomination from an un-related adult, who is an active member in good standing of a Washington State Federated Club
- An essay on your involvement in square dancing; how it has improved your life; how would you help square dancing grow, and why you deserve this scholarship
- A short paper telling us about yourself (hobbies, sports, family, goals, etc.), including your volunteer work

**Applications must be postmarked no later than April 30<sup>th</sup>**

Please send all applications by mail or email to the State Youth Coordinator:

Mail to: **Sierra Weber**  
1717 Wildflower Ct.  
Puyallup, WA 98374-1403  
253-686-2133  
Email: **p.dolphin1110@comcast.net**

## Youth Scholarship Application

Square and Folk Dance Federation of Washington, Inc.

Date: \_\_\_\_\_

Name: \_\_\_\_\_

Address: \_\_\_\_\_

City, State, Zip: \_\_\_\_\_

Phone: \_\_\_\_\_ Birth Date: \_\_\_\_\_ Age: \_\_\_\_\_

High School: \_\_\_\_\_ City: \_\_\_\_\_

Graduation Year: \_\_\_\_\_ Email: \_\_\_\_\_

**College or Trade School you will be attending:**

Name: \_\_\_\_\_

City & State: \_\_\_\_\_

Area of study or major: \_\_\_\_\_

**Club Affiliation(s):** \_\_\_\_\_

Council: \_\_\_\_\_ Number of years danced: \_\_\_\_\_

- **Only completed applications forms, including a letter of nomination, essay and personal description will be considered.**
- **All material must be received by April 30<sup>th</sup>.**

# WASHINGTON STATE FESTIVAL TONS OF FUN IN 2021



**2021 Washington 68th State Square Dance Festival**  
**Tons of Fun 2021 June 18-19, 2021 9am - 10pm**  
**Delta Hotel 3105 Pine St. Everett, WA**

Register on-line with  @ <https://festival.wasdf.org/>

## ENTERTAINER INFORMATION:

Caller Coordinator Steve Noseck  
**connorst\_1@msn.com**

Cuer Coordinator Karen Neverdowski  
**orbets@yahoo.com**

Vendor Coordinator Doug Keyes  
**KeyesDL7@gmail.com**

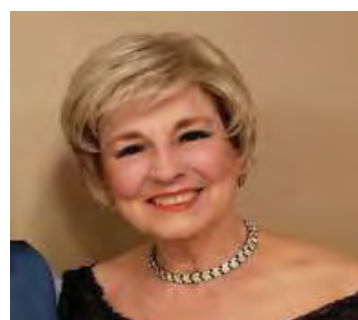

**Thursday, June 17th**  
 (see below)

**Friday, June 18th**  
**9:00 am – 10:00 pm**  
 ALL DANCE HALLS OPEN  
 MS, Plus, Advanced, Rounds,  
 Youth/High Energy and  
 Specialty Halls

REGISTRATION OPEN

**10:00 am – 10:00 pm**

VENDORS, SEWING,  
 & HERITAGE

**11:30 am – 12:30 pm**

HALLS CLOSED FOR LUNCH  
 PRE-BUY YOUR BOXED LUNCH  
 Glacier Room

**5:30 pm – 7:00 pm**

HALLS CLOSED FOR DINNER  
 PRE-BUY YOUR DINNER TICKETS

**Saturday, June 19th**  
**9:00 am – 10:00 pm**  
 ALL DANCE HALLS OPEN  
 MS, Plus, Advanced, Rounds,  
 Youth/High Energy and  
 Specialty Halls

**10:00 am – 10:00 pm**

VENDORS, SEWING,  
 & HERITAGE

**11:30 am – 12:30 pm**

HALLS CLOSED FOR LUNCH  
 PRE-BUY YOUR BOXED LUNCH  
 Glacier Room

**5:00 pm – 7:00 pm**

HALLS CLOSED FOR BANQUET DINNER  
 PRE-BUY YOUR DINNER TICKETS  
 PAGEANT AWARDS  
 President's, McNutt, Parker, & Youth Awards

*\*Sponsored by Mount Baker Council\**  
**TRAIL IN DANCE**  
**at Host Delta Hotel**  
**7 to 10pm on Thursday 6/17/21**

**CALLERS: Steve Edlund, Brent Mawdsley, Steve Noseck and Kevin Thomaier**

**CUER: Karen Neverdowski**

**M/S with 2 PLUS tips \$10.00 each at the door only**

## Brent Mawdsley

Brent, his wife Therese, and daughters Amanda and Megan are from Vancouver, BC, Canada.

Brent began calling at the age of 13 and danced and called in the Pacific Northwest Teen Square Dance Festival (PNTSDF) for five years. In 1984, while attending the University of BC and obtaining a B.Sc. in Chemistry, Brent became the caller/teacher for his first club, the Campus Cavaliers. Since 1988, he has called and cued two to four nights per week, and currently calls for four clubs, one of them for over 32 years. Brent is a member of Callerlab and calls and cues for dance weekends and special events throughout the Pacific Northwest as well as regularly entertaining community groups with introductions to modern square dancing. He is also a staff caller with Riverboat Square Dance Music and has made over 20 recordings.

Brent could not do all this without the love and support of his wife of over 28 years, Therese. In 2012 Brent and Therese were awarded the Caller Couple Scroll of Honour by the Vancouver area dancer association (FVS&RDA) in recognition of their dedicated service to the square dance community.

When he's not calling, Brent works full time as Business Development Manager, for Activation Laboratories, a global mineral testing company.

## Kevin & Linda Thomaier

With over 50 years of calling experience, Kevin regularly calls and teaches Mainstream thru A2 at his home programs. Along with his home programs, Kevin has called for numerous clubs in Washington, Oregon, Alaska, Nevada, Utah and Canada as well as Council and State Festivals as featured caller.

Kevin is a charter member of the Northwest Callers Association and has been a member of Callerlab since 1983.

Kevin and Linda started dancing in their early teens. They are honored recipients of the Washington State Parker Award and the Central Puget Sound Council Jack Willison Award.

Kevin & Linda reside on Lake Desire in Renton Washington and they will be celebrating their 47th Wedding anniversary this year.

Kevin and Linda have two daughters who have blessed them with six grandchildren.

## Steve Edlund

Steve began square dancing as a teenager with the rest of the neighbourhood kids as they joined their parents at the Surrey Square Wheelers. He tried calling at a Goofers' Night, and the rest, as they say, is history. As a member of the Wesburn Wranglers he won the Senior Champion at the Pacific Northwest Teen Square Dance Festival.

It is a pleasure to have later called for the Wesburn Wranglers for 18 years, as well as the Abbotsford Swinging Hubs, Lochdale and Silver Saddles Square Dance Clubs. Presently Steve is calling for the Royal Swingers (as he has for the past 35 years) as well as the Surrey Square Wheelers, and the Abbotsford Swinging Hubs (again).

Square dancing has brought many opportunities to Steve and he has had the opportunity to travel extensively throughout North America, Sweden, and Japan. He has also called in San Jose, Costa Rica and Oslo, Norway. Currently, Steve is on the staff of Elite Records, based in Houston, Texas, and Riverboat Records out of California. Steve has been calling for over 38 years and would not change a thing.

Steve lives in Surrey, British Columbia with his wife of 33 years, Lynnette. They are now empty nesters. Kristen, their daughter is teaching full time and was recently married. Outside of square dancing, Steve and Lynnette lead an active life biking, kayaking, golfing, and traveling.



**2021 Washington 68th State Square Dance Festival**  
**Tons of Fun 2021 June 18-19, 2021 9am - 10pm**  
**Delta Hotel 3105 Pine St. Everett, WA**

Register on-line with @ <https://festival.wasdf.org/>

<b>REGISTRATION:</b>	until 12/31/20	after 01/01/21	<b>MEALS:</b>	Friday	Saturday
Adult	\$50.00	\$60.00	Lunch	\$15.00	\$15.00
Teen	\$25.00	\$30.00	Dinner	\$30.00	\$30.00
Family	\$125.00	\$150.00	Meals are Optional		

Name \_\_\_\_\_ Address \_\_\_\_\_  
 City \_\_\_\_\_ State \_\_\_\_\_ Zip \_\_\_\_\_  
 Email \_\_\_\_\_ Phone \_\_\_\_\_

**DANCER LEVEL** (check all) \_\_\_ M/S \_\_\_ Plus \_\_\_ Advanced \_\_\_ 2/3Rounds \_\_\_ 4/5 Rounds

Last Name	First Name	Adult	Teen	Family	WA Badge\$5	Lunch\$15	Dinner\$30	Total
<b>TOTAL</b>								

**FOOD** Select choice and the number of meals:

**Friday Box Lunches**

- ( ) Turkey,
- ( ) Beef,
- ( ) Vegetarian

**Friday Dinner**

- ( ) Pasta Buffet

**Dietary Limitations**

\_\_\_\_\_  
 \_\_\_\_\_

**Saturday Box Lunch**

- ( ) Turkey
- ( ) Beef
- ( )Vegetarian

**Saturday Banquet Awards Dinner**

- ( ) Chicken
- ( ) Beef
- ( )Vegetarian

**MAIL REGISTRATION TO:**  
 Sheryl Long  
 10922 - 132nd Av NE  
 Redmond, WA 98052

Make checks payable to: **2021 WA State Festival**

## ENTERTAINER INFORMATION:

Caller Coordinator Steve Noseck

[connorst\\_1@msn.com](mailto:connorst_1@msn.com)

Cuer Coordinator Karen Neverdowski

[orbets@yahoo.com](mailto:orbets@yahoo.com)

Vendor Coordinator Doug Keyes

[keyesDL7@gmail.com](mailto:keyesDL7@gmail.com)

**CALLERS & CUERS** (check all levels you want to call/cue)

Caller  Cuer  M/S  Plus  Advanced  2/3  4/5 Rounds

## HOTEL ACCOMMODATION INFORMATION:

**HOST HOTEL Delta Hotels by Marriott** (425) 339-2000

Ask for "Square Dance Festival 2021" RATE: \$155/night FREE parking & breakfast  
book at [Jennifer.Leyda@Marriott.com](mailto:Jennifer.Leyda@Marriott.com) or <https://tinyurl.com/TonsofFun2021Hotel>

**Courtyard by Marriott Everett** 3003 Colby Av. Everett, WA 98201 (425) 259-2200

(0.8mi.) RATE: \$139.00/night king \$159.00/night 2 queens NO BREAKFAST

**Hampton Inn Seattle/Everett** 2931 W Marine View Dr. Everett, WA 98201

(425)349-4466 (1.1mi) RATE: \$140.00/night FREE breakfast

**Best Western Cascadia Inn** 2800 Pacific Av. Everett, WA 98201 (425) 258-4141

(1.5 blks) RATE: \$119.00/night FREE breakfast

**No Camping on site. Find available camping on-line.**

## NOTES:

\*Refunds available until May 31st, 2021 less \$10.00

\*Ribbons will be mailed to the address listed above

\*Festival Bars are included with registration

\*WA State Badge available for \$5.00 purchase

**FOLLOW US:** **Web:**<https://festival.wasdf.org/>

**Facebook:** <https://www.facebook.com/WAsdfestival/>

*\*\*Sponsored by Mount Baker Council\*\**  
**TRAIL IN DANCE**  
**at Host Delta Hotel**  
**7 to 10pm on Thursday 6/17/21**  
**CALLERS: Steve Edlund, Brent Mawdsley,**  
**Steve Noseck and Kevin Thomaier**  
**CUER: Karen Neverdowski**  
**M/S with 2 PLUS tips**  
**\$10.00 each at the door only**

# 70<sup>TH</sup> NATIONAL SQUARE DANCE CONVENTION

## Mississippi Heartland Trivia

### Did you know . . .



1. Author Eudora Welty's birthplace at 741 N. Congress Street in Jackson is located directly across the street from the childhood home of novelist Richard Wright. Only in Mississippi, the state known for its literary heritage, will you find the childhood homes of two Pulitzer Prize-winning authors across the street from one another.
2. Country music superstar and Cover Girl model Faith Hill grew up in Star, Mississippi, and was briefly enrolled at nearby Hinds Community College.
3. Bob Pittman, founder of MTV, is a native of Brookhaven, Mississippi.
4. The late actress Beah Richards was a resident of Vicksburg. Richards's final performances included a role in Oprah Winfrey's *Beloved* and an Emmy-winning guest performance on TV's *The Practice*.
5. The late actor Michael Clarke Duncan attended college at Alcorn State University in Lorman. His heartbreaking performance in *The Green Mile* earned Duncan an Oscar nomination.
6. The world's first human heart and lung transplants were performed in 1964 in Jackson at the University of Mississippi Medical Center.
7. Neatniks worldwide owe a debt of gratitude to Harry Cole, Sr., of Jackson, the inventor of Pine-Sol.
8. Upon its completion in 1925, the ten-story Lamar Life Building (317 East Capitol St.) was hailed as Jackson's first skyscraper.
9. Tipping the scales at more than eighteen pounds, the state record largemouth bass was reeled in from Natchez State Park Lake in 1992.
10. Mississippi boasts more churches per capita than any other state.

### *Jackson & Missy* 70<sup>th</sup> NSDC Ambassadors



*(Source: Off the Beaten Path Mississippi by Marlo Carter Kirkpatrick)*



# NATIONAL SQUARES E-MAGAZINE

<http://www.nsdcnec.com/flipdocs/NatSqOnline/Natsq1020/index.html>



## NATIONAL SQUARES E -MAGAZINE

Volume 12

Issue 3

October 2020

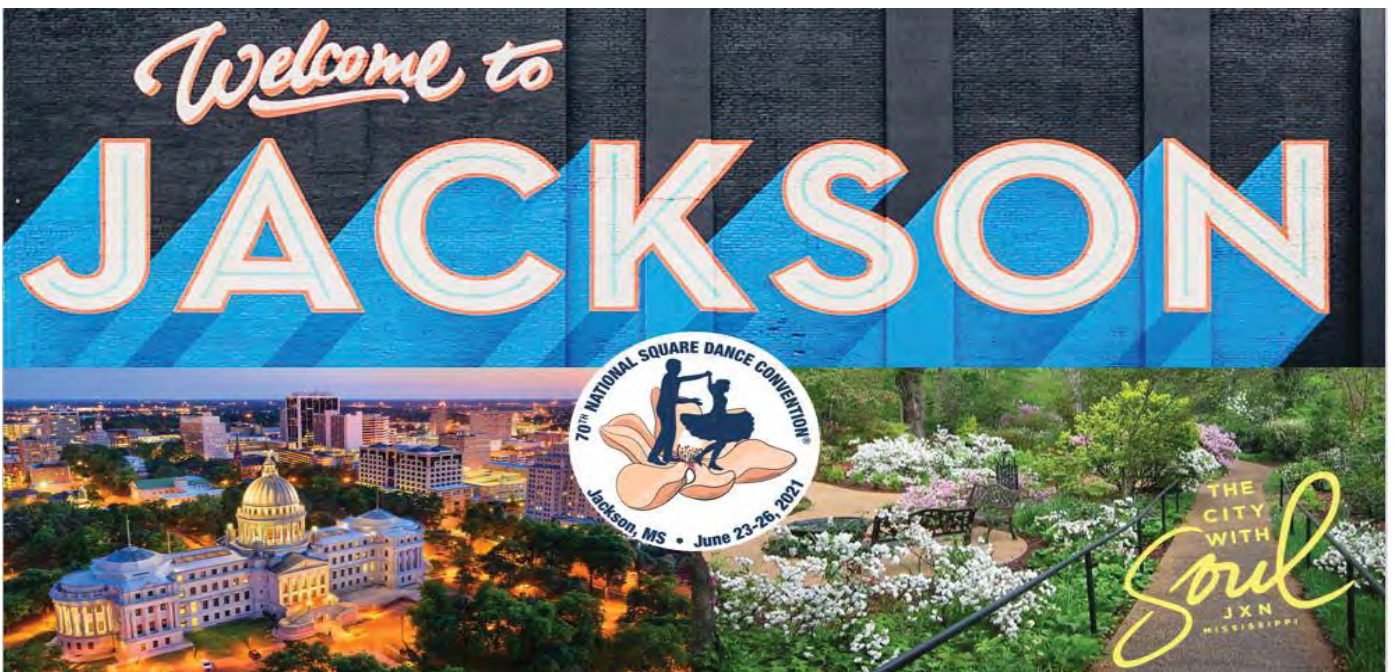

*Dancing Fun in 2021 in the City with Soul!*

**70<sup>th</sup> National Square Dance Convention®**

**June 23 – 26, 2021**

**Jackson, Mississippi**

**[www.70nsdc.com](http://www.70nsdc.com)**





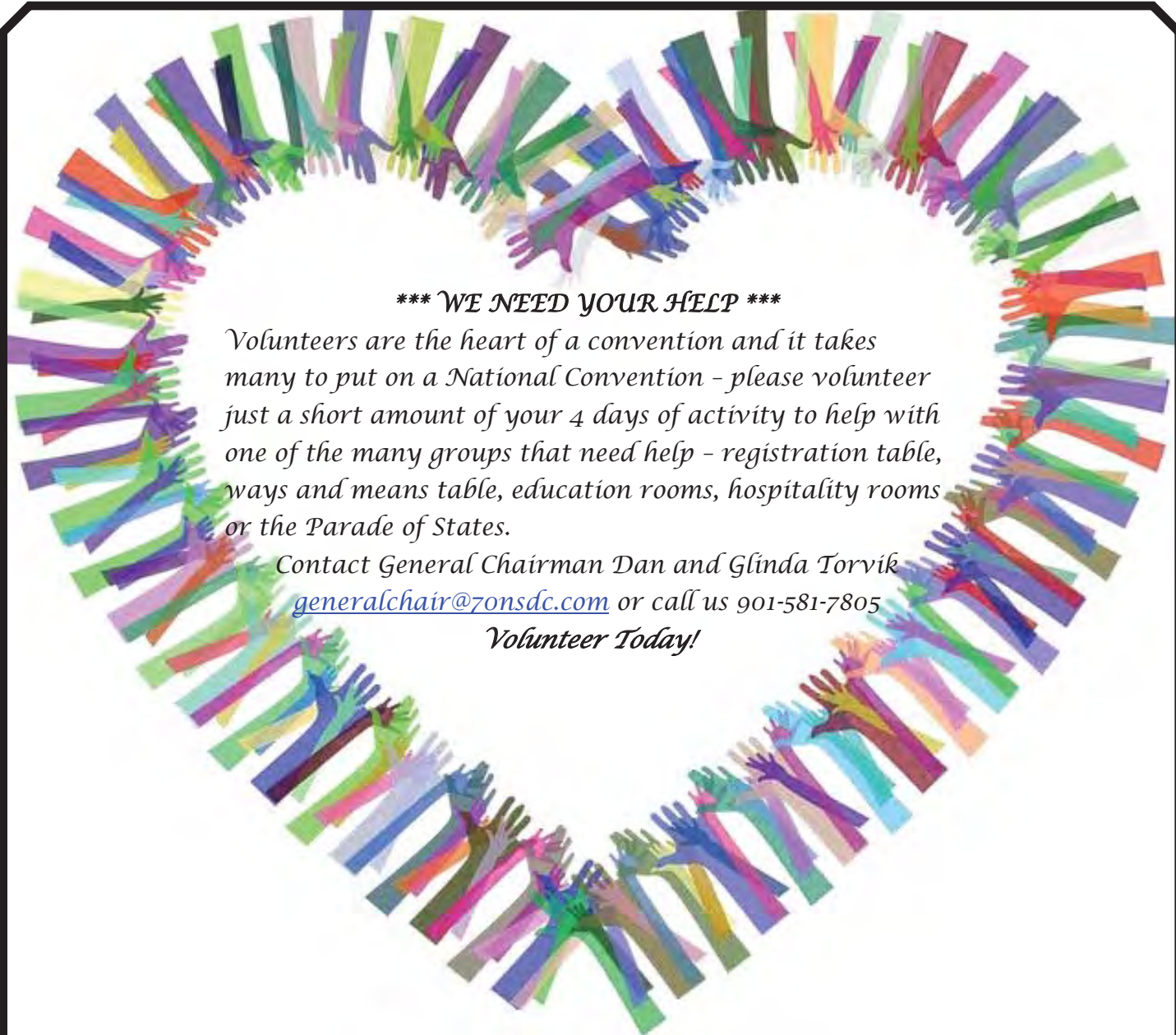

**\*\*\* WE NEED YOUR HELP \*\*\***

*Volunteers are the heart of a convention and it takes many to put on a National Convention - please volunteer just a short amount of your 4 days of activity to help with one of the many groups that need help - registration table, ways and means table, education rooms, hospitality rooms or the Parade of States.*

*Contact General Chairman Dan and Glinda Torvik  
[generalchair@70nsdc.com](mailto:generalchair@70nsdc.com) or call us 901-581-7805*

*Volunteer Today!*



**FASHION SHOW**

**AT THE 70<sup>TH</sup> NSDC**

Would you like to Jump on Board the "City with Soul" train to be a model in our Fashion Show to show off your favorite outfit? If so, please contact our Fashion Show Vice-Chairman, Linda Carlile at 903-277-8681 or [specfashion@70nsdc.com](mailto:specfashion@70nsdc.com). There will be a practice session on Saturday morning June 26, 2021.



# World of Meals!

A Cookbook by Dancers from Around the World

Order your copy of the World of Meals Cookbook before we are sold out so you can enjoy all the great recipes from around the world.



Have you ever wanted to try a new dish from somewhere else . . . not just the same old stuff? Here is an awesome cookbook by dancers from around the world. Tried and true recipes from your fellow dancers. Enjoy over 400 recipes submitted by dancers, callers, and cuers from all 50 states and nine foreign countries – everything from a typical Hawaiian dinner to a 3-course Australian dinner and much more. We have even included over 14 meal plans to ease the stress of balancing the meals.

**Cost: \$15    Postage: \$3**

[CLICK HERE](#) to visit our website and purchase your copies today!

This cookbook is a thoughtful gift for Christmas, weddings, or surprise someone with one for their birthday.



# The United Square Dancers of America's Social Media Committee Proudly Introduces Our New Zoom Series



## *Beyond the Dance Floor*

**Dancing** — We all miss dancing! The great news is, as a community we've been adapting to "the new normal". It's been wonderful to see callers and cuers set up virtual dance events. Online groups have been set up to discuss returning to dancing and what precautions need to be taken. IAGSDC even transitioned their International Convention into a "home edition" with virtual dancing and live online activities. Happily, in some areas of the country, clubs are cautiously and carefully beginning to dance again, but there is still more to do.

The **United Square Dancers of America** — USDA — your National dancers' organization, is excited to introduce a monthly series of web-based programs via *Zoom* to support clubs on the business and marketing end of our activity. The programs will be used to introduce more dancers across the country to who/what USDA is, the programs and services we provide, and a way to keep square and round dancing in the forefront of people's thoughts even if they aren't able to get together on the dance floor.

**Beyond The Dance Floor** – It takes a lot of effort and organizational skills to keep our favorite activity alive and USDA is here to help. From bylaws to event planning, club officer duties, promotion, communications, newsletters, youth and handicapped programs – this series is designed to help groups across the country build and grow your clubs.

**Workshops** are scheduled to last 90-minutes to allow plenty of time for questions & answers, plus we will welcome input from participants. Our first workshop launches on Saturday, October 10th and our complete schedule is listed on the subsequent pages.

Watch your email, our website and Facebook for links to the actual, **FREE** workshops.



**For more information or to check on scheduling updates, please contact us at:**

USDA Social Media Directors: Milene [McCall—mm101@msn.com](mailto:McCall—mm101@msn.com)

Bonnie Abramson - [bjabramson@gmail.com](mailto:bjabramson@gmail.com)

Or visit our Facebook page and join our Facebook group

<https://www.facebook.com/groups/314405916617> (United Square Dancers of America—USDA)





## NEW USDA WEBINAR PROGRAM: BEYOND THE DANCE FLOOR

We are all anxious to get back to dancing on a regular basis, but one thing we CAN do now is learn more about what happens **Beyond the Dance Floor!** The United Square Dancers of America is excited to introduce a brand-new series of web-based sessions on “behind the scenes” programs and services that support dancing around the country, and help us communicate about and grow our favorite activity. These monthly 90-minute interactive webinars be held via Zoom and will take place on Saturdays at 2:00 Eastern Time / 11:00 Pacific Time. The series launched on Saturday, October 10 with an introductory webinar on the basics of USDA. Upcoming topics include:

- November 14: USDA’s 501(c)(3) Group Exemption Program
- December 12: USDA Youth Dancer Programs and Founders’ Memorial Youth Scholarship
- January 16: Do You Hear What I Hear? Using Newsletters & Social Media to Get the Word Out
- February 13: Promoting Square Dancing During the Most Challenging of Times, with Mike Hogan

Check the USDA website ([www.usda.org](http://www.usda.org)) as well as the USDA Facebook group for further detail. Zoom log-in information will be shared the week before each session. Questions may be directed to Bonnie Abramson, USDA Co-Social Media Director, at [bjabramson@gmail.com](mailto:bjabramson@gmail.com), or Sally Bennett-Schmidt, USDA Information Officer, at [usda.information.officer@usda.org](mailto:usda.information.officer@usda.org).



# IT'S TIME TO REGISTER FOR THE 70<sup>TH</sup> NSDC



We are **counting** on you  
but we need your registration so we can make plans!

If you have not already, submit your registration today!

We are looking for a crowd since the 69<sup>th</sup> NSDC was canceled. The National Convention is a place that many people see some of their square dance friends once a year. Come Early or Stay Late! The 70<sup>th</sup> NSDC Soul Team is committed to making our Convention a fun and memorable experience for you.

[CLICK HERE](#) to Register Online or to download a Mail-In Registration Form. From this link you can also book your hotel room or campsite, sign up for the awesome Wednesday Special Event with Elvis and meal, check out all the tours available, book the post-convention cruise and purchase Convention T-shirts.

**On the 70<sup>th</sup> NSDC website:**

Click on [Registration](#) to register

Click on [Housing](#) for Hotel & Camping  
**Need help?**

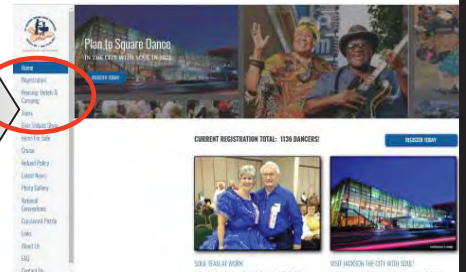

Please do not hesitate to contact Mary Ann Walker, Registration/Housing Chairman. [regchair@70nsdc.com](mailto:regchair@70nsdc.com) or 901-628- 4356

**Please note:** If you choose to Register by mail, download your registration form from the website to your computer. Then print a copy, complete the Registration Form and mail to the address on the form.



## Everything Elvis

### Pre-Convention Tour June 20-23, 2021

Elvis Presley who was arguably the world's greatest entertainer, was born in Mississippi. His history has been preserved and you can't miss it! Sunday, we travel to the city of his birth – Tupelo. After checking into our hotel, we will get some dinner. Afterwards, we will have some time to walk about town or do some shopping. On Monday morning, we will tour the **birthplace of Elvis** and other sites where he walked. We will have lunch prior to leaving town and continue our tour by driving to Memphis, TN. We will check into our hotel near Graceland for 2 nights. After dinner, we will go see the unusual pyramid shaped **Bass Pro Shop**, with time to shop! On Tuesday, we begin our day with a tour of **Sun Studio**, where Elvis recorded his music. Next, we will drive past **Levitt Shell** - where Elvis performed his first paid concert. In the afternoon we will spend time at **Graceland** to see Elvis' home. You can also see his airplanes, automobiles, and other Elvis collectables. That night, we drive to **Beale Street**, where Elvis spent time with musicians gathered there. This is one of the most iconic streets in America. It is 3 blocks of restaurants, shops, and nightclubs. You will have time to explore this fun area and to have dinner on



your own. Wednesday morning, we will drive past a couple of other of Elvis's homes, prior to departing Memphis. On our way back to Jackson, we will stop for lunch. We arrive back in Jackson in time for the Wednesday night special event – an Elvis tribute artist (separate admission).

**Cost: \$650 per person double**  
**\$850 Single price**  
**Leaves at 1PM from downtown hotel or convention center.**  
**Be sure to arrive by 12:30PM.**  
**Includes bus, guide, admissions, and lodging. Meals included: 3 breakfasts at hotels, 3 lunches, and 2 dinners.**



**Please look at our**  
**Post-Convention Cruise to**  
**the Caribbean, departing**  
**from New Orleans. It is**  
**on a separate brochure**  
**or call 812-969-2307 for**  
**more information.**



## 70<sup>th</sup> National Square Dance Convention®



Dancing Fun in 2021 in the "City with Soul"

### Jackson, Mississippi Tours 2021

Tours included in this Brochure

- 🎵 Jackson City Tour
- 🎵 Armed Forces Tour
- 🎵 Sing the Blues Tour
- 🎵 Flash Mob Tour
- 🎵 "The Help" Cooking Tour
- 🎵 Meridian Tour
- 🎵 Mississippi Delta Tour
- 🎵 Natchez Tour
- 🎵 Vicksburg Tour
- 🎵 Everything Elvis, Pre-Convention

## Armed Forces Tour

This tour is for our military men and women and all enthusiasts. We will visit the **Armed Forces Museum** in Camp Shelby near Hattiesburg. The museum has galleries with exhibits from the late 19<sup>th</sup> century conflicts. Military weapons, equipment, clothing, and medals are on display. There is an outside display of aircraft, tanks, and field artillery. After time at the museum, we will eat lunch at **Crescent City Grill** before returning to Jackson.



**Tour days: Thursday June 24 and Saturday, June 26, 2021**

**Time: 9AM – 4:00PM Cost: \$79 pp**  
**Includes: Bus transportation, guide, admission, and lunch**

## Jackson City Tour

Enjoy a narrated overview of the city of Jackson, the “City with Soul.” It is known as the “City with Soul” because of her perseverance and her triumphant spirit. She’s birthed many historical marks that have shaped this country and beyond, from Civil Rights to Civil War, to music, and to world-class museums and exhibits. We will visit the capital and other interesting sights.

**Tour days: Tuesday-Friday, June 22-25, 2021**  
**Time: 9AM - 1PM Cost: \$43 pp**  
**Includes: Bus transportation and escort**

## Sing the Blues Tour

The Mississippi Delta may be the birthplace of the blues and where the blues live on! You will experience the blues on this tour. We will travel to Indiana to see the **BBK Museum**, a tribute to BB King, the King of the Blues. He was laid to rest here in 2015. Afterwards enjoy lunch and a blues concert at **Club Ebony**. On our way back to Jackson we will stop at the **Pecan House**, where you can treat yourself to a pecan delicacy.



**Tour days: Thursday, June 24, 2021**

**Time: 8AM-4:30PM Cost: \$83 pp**  
**Includes: Bus transportation, guide, admission, and lunch.**

**All Tour Information**  
**Call (812) 969-2307**

*Note: Tours not meeting minimum #'s by May 20, 2021 may be cancelled and then your money will be refunded. Tours meeting the minimum numbers may still be available at the Convention until sold out. Tours cancelled by guest will be assessed \$10 Cancellation Fee. There will be no refund, for any reason, for a “no-show” on the day of the tour.*

## “The Help” Cooking Tour

If you like to cook, this tour is for you! We will be traveling to Greenwood to take a class at the **Viking Range Company**, which will demonstrate how to make the southern dishes featured in the movie “The Help.” Then you get to enjoy this food. After lunch, we will spend some time shopping on Howard Street, which features some of the best shopping in the Delta region. Before we leave Greenwood, we will drive past several of the locations in the film, “The Help.”



**Tour days: Friday, June 25, 2021**

**This tour is limited to 35 people.**  
**Time: 8AM – 6PM Cost \$112 pp**  
**Includes: Bus transportation, guide, admission, and lunch.**

## Flash Mob Tour

Time to dance! Our bus will take us to several locations around the city to dance a tip or two. We will share our love of square dancing with the people of Jackson!

**Tour days: Saturday, June 26, 2021**  
**Time: 9AM - 1PM Cost: \$35 pp**  
**Includes: Bus transportation and caller**

## Meridian Tour

Meridian is a town rich in arts and entertainment. You will visit the **Mississippi Arts and Entertainment Experience**. Here they honor the state's legends via high-tech, interactive multimedia exhibits, themed galleries, and hands-on activities. We will have lunch at **Weidmann's**, serving excellent Southern cuisine. It is the oldest restaurant in Mississippi and one of the oldest in the United States. It is home of the Black Bottom Pie.



After lunch we will tour **Merrehope**, one of the few antebellum homes remaining in Meridian. It was built in 1858. It still stands despite General Sherman saying that "Meridian no longer exists." Prior to leaving Meridian, we will stop for a ride on the **Dentzel Carousel**.

**Tour days: Thursday & Friday, June 24-25, 2021**  
**Time: 8:30AM – 5:30PM Cost: \$92 pp**  
**Includes: Bus transportation, guide, admission, and lunch.**

**Tour info and registration can also be found on our website at:**

**70nsdc.com**

## Mississippi Delta Tour

Travel the roads of the Mississippi Delta and you will find that every stop has its own character and worthy of exploration. It may be the birthplace of the blues. First, we travel to Cleveland to see the **Grammy Museum**, the most technologically advanced music-themed museum in the South. From here we travel to Clarksdale, past the "**Crossroads**,"



where a blues legend sold his soul to the devil. We lunch at the **Ground Zero Blues Club**, where the blues got its start. Morgan Freeman is a co-owner! After lunch, we tour the **Delta Blues**



**Museum**, where you can find a large collection of blues artifacts. On our way back to Jackson, we stop in Indianola at the **Pecan House**, where you can treat yourself to a pecan delicacy. We then drive past **Club Ebony**, learning of its past.



**Tour days: Wednesday June 23, 2021**  
**Time: 7:30AM – 7:30PM Cost: \$105 pp**  
**Includes: Bus transportation, guide, admission, and lunch.**

## Natchez Tour

We depart Jackson and travel to Natchez. It sits on the banks of the majestic Mississippi River. In the mid-1800's two cities vied for the most millionaires - Natchez and New York. See some of the most beautiful homes in America from the time period. At over 30,000 sq. feet, **Longwood** is the largest octagonal house in America and still unfinished since 1861. Feel the desolation of the war, seeing paint cans and nail kegs still in place. See

**Melrose** including the slave quarters and carriage house.



**Stanton Hall** is one of Natchez most opulent houses. We will have lunch in the



**Carriage House Restaurant**, located in Stanton Hall. On our way home, we will make

a brief stop at **Emerald Mounds**, the second largest ceremonial mound in the US.



**This tour has lots of walking & stairs.**

**Tour days: Wed – Friday, June 23-25, 2021**  
**Time: 8AM – 6PM Cost: \$121 pp**  
**Includes: Bus transportation, guide, admission, and lunch.**



## Vicksburg Tour

Abraham Lincoln called Vicksburg “the key” to ending the Civil War. The defeat in this city was a turning point in the war and the city’s significant role is made evident when touring the **Vicksburg National Military Park**. See the battlefield with over 1,340 monuments, including a stop to see the USS Cairo Museum – an ironclad struck by two underwater torpedoes in the war. Lunch today will be at **Walnut Hills Restaurant**, featuring southern plantation cuisine. After lunch we visit the **Old Court House Museum**, filled with items reflecting Southern Heritage, including the largest Civil War memorabilia in the South.



**Tour days: Thursday, June 24 and Friday, June 25, 2021**  
**Time: 8AM – 5PM**      **Cost: \$99 pp**  
**Includes: Bus transportation, guide, admission, and lunch.**

<u>Tour Registration</u>	<u>Time</u>	<u>Cost</u>	<u># of Tickets</u>	<u>Total</u>
Everything Elvis <b>Tuesday, June 22</b>	Sunday 1pm	\$650 pp double or \$850 single	_____	_____
Jackson City Tour <b>Wednesday, June 23</b>	9am-1pm	\$43	_____	_____
Jackson City Tour	9am-1pm	\$43	_____	_____
MS Delta Tour	7:30-7:30	\$105	_____	_____
Natchez Tour	8am-6pm	\$121	_____	_____
<b>Thursday, June 24</b>				
Jackson City Tour	9am-1pm	\$43	_____	_____
Armed Forces Tour	9am-4:00	\$79	_____	_____
Sing the Blues Tour	8am-4:30	\$83	_____	_____
Meridian Tour	8:30-5:30	\$92	_____	_____
Natchez Tour	8am-6pm	\$121	_____	_____
Vicksburg Tour	8am-5pm	\$99	_____	_____
<b>Friday, June 25</b>				
Jackson City Tour	9am-1pm	\$43	_____	_____
The Help Cooking Tour	8am-6pm	\$112	_____	_____
Meridian Tour	8:30-5:30	\$92	_____	_____
Natchez Tour	8am-6pm	\$121	_____	_____
Vicksburg Tour	8am-5pm	\$99	_____	_____
<b>Saturday, June 26</b>				
Armed Forces Tour	9am-4:00	\$79	_____	_____
Flash Mob Tour	9am-1pm	\$35	_____	_____
<b>Grand Total:</b>			\$	_____

All participants in activities and use of Facilities shall be undertaken by each individual at his or her own risk. The 70<sup>th</sup> NSDC shall not be liable for any claims, damages, actions or causes of actions whatsoever to person or property arising out of or connected to the use of any service or facilities arranged for or the premise where the same are located or arising out of acts of active or passive negligence by agents or volunteers of the 70<sup>th</sup> NSDC. Personal items and souvenirs are the sole responsibility of the tour patron.

**Please make checks out to: 70<sup>th</sup> NSDC or enclose credit card information and mail to:**  
**8538 Lotticks Corner Rd SE Elizabeth, IN 47117**      Cancellation Fee is \$10 per person.

Name \_\_\_\_\_ Address \_\_\_\_\_  
 City \_\_\_\_\_ State \_\_\_\_\_ ZIP \_\_\_\_\_  
 Phone (\_\_\_\_) \_\_\_\_\_ Email \_\_\_\_\_  
 Check enclosed for \$ \_\_\_\_\_ Card Number \_\_\_\_\_  
 Expiration Date \_\_\_\_\_ Security Code (3 numbers on back) \_\_\_\_\_  
 Special Needs – physical, dietary? \_\_\_\_\_  
 Emergency Contact Name \_\_\_\_\_ Phone \_\_\_\_\_

### INSTRUCTIONS FOR REGISTRATION (LEFT FRONT SIDE OF FORM)

1. Print legibly all names, address, city, state, zip code, country, and B/D of youth (age 5-17 by June 26, 2021 discounted price) to ensure correct registration.
2. Correctly enter all amounts in the Subtotals, including registration fee for each dancer plus quantity and amounts for all other materials. Calculate the Total and include credit card information, check or money order payable in U.S. funds to the 70th National Square Dance Convention® and return it with the Registration Form. **Do Not Send Cash.** No Single Day Registrations.
3. A \$10.00 fee per registrant will be assessed for cancellation. No refunds after April 30, 2021.
4. **Important! Daily schedules are only available with the purchase of a Program Book. Daily schedules will not be available separately at the Convention. Most dancers will want to purchase the Program Book.**
5. TOUR FORM AND PAYMENT INSTRUCTIONS: Please complete the Tour Order Form and mail directly to: Dream Vacations (70th NSDC), 8538 Lotticks Corner Rd SE, Elizabeth IN 47117. For any questions call 812-969-2307 or email to [c.schoen@dreamvacations.com](mailto:c.schoen@dreamvacations.com). For Tour information and Order Form go to [www.70nsdc.com](http://www.70nsdc.com) and click "TOURS"

### INSTRUCTIONS FOR RV/CAMPING

Indicate RV Camping on your registration form and enclose the required fees (4-night minimum) to cover the nights that you intend to stay. 30 or 50 Amp and water available at all sites with sewer at most sites. Free dump station on site. If you plan to camp together, you must arrive together. For more information contact RV Vice-Chairman, John & Dolly Ide [regcampingrv@70nsdc.com](mailto:regcampingrv@70nsdc.com).

### INSTRUCTIONS FOR HOUSING (RIGHT FRONT SIDE OF FORM)

1. The 70th NSDC Housing Committee is pleased to offer website online access for housing reservations available after March 1, 2020. If you book your room online, check the box provided on front side of this form; otherwise complete the entire housing portion on the right side of the front of this form. This form must be received by May 15, 2021 to guarantee the 70th NSDC pricing.
2. Indicate three (3) choices of hotel preference by specifying hotel code number. Also, be sure to indicate 1 bed (Standard King) or 2 beds (Queen). Hotels will be assigned on a first-come, first-serve basis according to availability.
3. Only one person per room should complete a hotel reservation request on the front of this form. Please list all room occupants. (The Housing Committee does not find or assign roommates.)
4. Shared Room or Same Hotel Requests can be made through the online site OR forward registrations together in the same envelope.
5. All Block Housing requests staying in the same hotel are due by January 2, 2021, include the name and telephone number of Block Leader to [reghousing@70nsdc.com](mailto:reghousing@70nsdc.com)
6. Hotel Reservations: Your reservations must be guaranteed with a credit card and a \$3.50 non-refundable processing fee. The hotel may require an advance deposit for 1st night. The balance will be paid at the hotel. An alternative form of payment may be presented at check in. Ensure expiration date is after July 2021.
7. Hotel Confirmations: You will receive a hotel confirmation from the 70th NSDC via email or mail. A Hotel confirmation will be sent after March 1, 2021. If you do not receive your confirmation by March 30, 2021, please contact the Housing Committee by email at [reghousing@70nsdc.com](mailto:reghousing@70nsdc.com)
8. Hotel Changes: After receiving Hotel Confirmation, if you need to modify your hotel reservation you must contact the 70th NSDC Housing Committee, [reghousing@70nsdc.com](mailto:reghousing@70nsdc.com)
9. Hotel Cancellations: Your confirmed hotel will assess a one-night room/tax charge for cancellations received less than 72 hours prior to arrival.
10. Hotel Early Departure: An early departure fee may be charged unless the 70th NSDC Housing Committee [reghousing@70nsdc.com](mailto:reghousing@70nsdc.com) is notified at least 72 hours prior to a change in the planned stay.

**BUS PASS AVAILABLE IF NEEDED**

### Map of Hotels

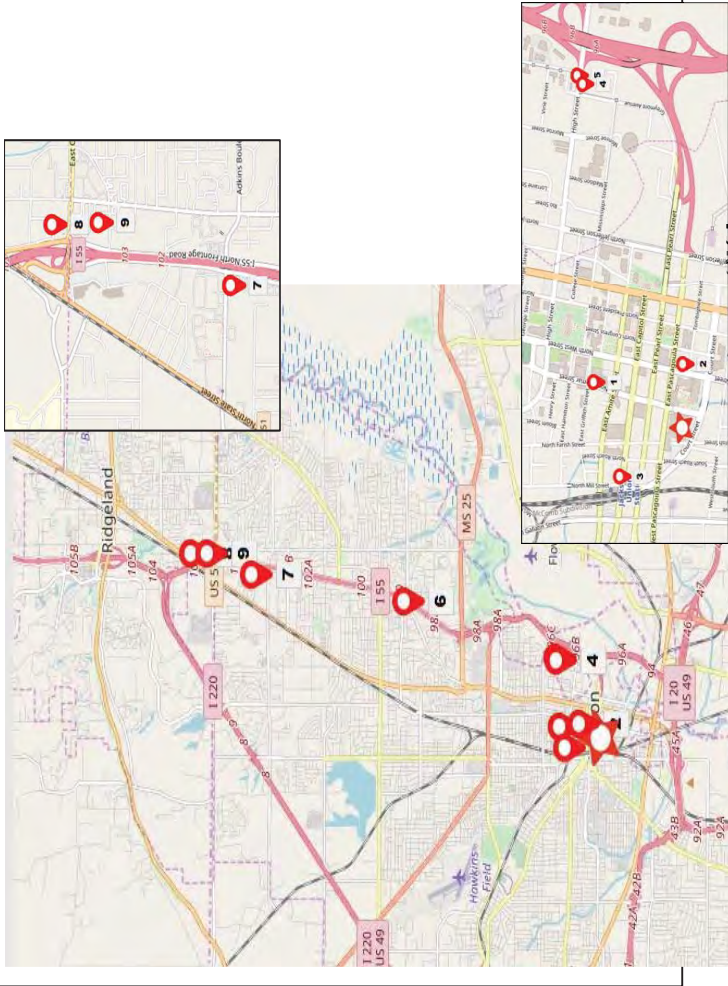

Code	Hotel Name * parking fee ** 1 night deposit at time of reservation	1 person	2 people	3 people	4 people	Distance
1	Jackson Downtown Convention Center Hotel	\$139	\$139	\$149	\$159	.3 miles
2	by Marriott Headquarters Hotel	\$159	\$159	\$169	\$179	.3 miles
3	Westin Downtown **	\$139	\$139	\$149	\$159	.2 miles
4	Hilton Garden Inn (Callee/Cuer) *	\$102	\$102	\$102	\$102	1.4 mile
5	Hampton Inn & Suites **	\$129	\$129	\$129	\$129	1.4 mile
6	Holiday Inn Express **	\$150	\$150	\$150	\$150	3.7 miles
7	Residence Inn **	\$80	\$80	\$80	\$80	7.7 miles
8	Oyo Townhouse **	\$119	\$124	\$129	\$134	9 miles
9	Hilton Jackson	\$129	\$129	\$129	\$139	7 miles
	Courtyard Jackson/Ridgeland					



**Jackson Convention Complex 105 E Pascagoula St, Jackson, MS 39201**

**Return completed form with payment to:**

**70th NSDC, 5252 McIngvale Rd., Hernando, MS 38632**

**Any questions, please call 901-628-4356**

Come Early or Stay Late! The Soul Team of the 70th NSDC is committed to making our Convention fun and memorable experience for you. Please email us if you have a concern or suggestion.  
Dan and Glinda Torvik, General Chairman, [generalechair@70nsdc.com](mailto:generalechair@70nsdc.com)



The Indiana "River Rats" invite you to:  
Make fast tracks to the  
71st National Square Dance Convention®

Evansville, Indiana  
June 22 - 25, 2022



**Preregister now for the 71st NSDC  
go to [71NSDC.org](http://71NSDC.org) to register online or download  
PDF form for mailing.**

**Your registration ribbon includes admission to the  
preconvention dance on March 13th, 2021**



**Dino Martino Says:  
"Make tracks to the 71st NSDC In  
Evansville, IN. June 22-25, 2022.  
*I'm ready to process your registration."***





Dancing Fun in 2021 in the "City with Soul"

The "OFFICIAL"

Jackson Post-Convention Cruise – June 27, 2021



Dancing Fun in 2021 in the "City with Soul"

# Dancing is FUN in the Sun

Join us on Carnival's **FUN** ship "Glory" to the Eastern Caribbean



**Justin Russell**



**Mike Hogan**

Featuring

After the convention we invite you to go dancing aboard the *Glory* out of New Orleans to Key West, Freeport, and Nassau. You will have 3 days at sea to dance with these amazing callers, and even more **FUN!**



### Double Occupancy

Interior - \$1,013 per person\*

Oceanview - \$1,133 per person\*

Balcony - \$1,423 per person\*

\*Price includes Port Charges, Current Taxes and fees & **Gratuities**. (Insurance recommended – extra cost.)

### Itinerary

- June 27 – Depart New Orleans 3:30 pm
- June 28 – Dancing at Sea
- June 29 – Key West 8am – 4pm
- June 30 - Freeport 8am – 5 pm
- July 1 – Nassau 7am-5pm
- July 2 & 3 – Dancing at Sea
- July 4 – Arrive New Orleans 8am



**Call Cindy Schoen for information or to book at 812-969-2307**

Email: [c.schoen@dreamvacations.com](mailto:c.schoen@dreamvacations.com)



Call Cindy Schoen for Information or to book:  
**812-969-2307**

**PLEASE READ CAREFULLY**

**Note: Airfare available Call for details.**

**Deposit:** A deposit of **\$250.00** per person is required to secure a stateroom. **Received not later than: January 8, 2021**

**Final Payment:** The balance remaining after deposit is due on or before **March 12, 2021**

**Cancellations and Refunds:** Administration Fee plus any cruise line penalty fee will be assessed.

**Bookings: Must be made with Cindy Schoen of Dream Vacations to take part in any "Dancing is Fun in the Sun" activities and participation privileges are NOT transferable.**

**Required documentation:**

- ❖ US citizens – Valid Passport
- ❖ Boarding Pass from online registration

**Some of what to expect:**

- ❖ Free entertainment including Vegas style productions, live music in various locations,
- ❖ Fine dining, buffets, and room service
- ❖ Waterworks, Hot Tubs, Swimming Pools, Mini golf, Shuffleboard, Dive-in Movies
- ❖ Square Dancing onboard
- ❖ Free "Dancing is Fun in the Sun" T-Shirt (one per person)
- ❖ Lots of FUN activities
- ❖ **\$50/stateroom Ship Board Credit**

**Not included:**

**Alcoholic beverages and soft drinks**  
**Spa and beauty salon services**  
**Personal items, souvenirs, etc**  
**Shore Excursions, Casino play**  
**Transfer to/from Port**  
**Insurance (recommended) – Currently cost:**  
**\$79pp Interior, \$95 O/V, \$99pp Balcony**

**Complete and mail form to: Dream Vacations 8538 Lotticks Corner Rd SE Elizabeth, IN 47117**

Legal (first, middle, last)      US Citizen Yes \_\_\_\_\_ No \_\_\_\_\_ (if no what country) \_\_\_\_\_

Name (s) \_\_\_\_\_ Date of Birth \_\_\_\_\_  
\_\_\_\_\_ Date of Birth \_\_\_\_\_

Address \_\_\_\_\_

City \_\_\_\_\_ State \_\_\_\_\_ Zip \_\_\_\_\_ Country \_\_\_\_\_

Telephone (home) \_\_\_\_\_ (work/cell) \_\_\_\_\_

Email \_\_\_\_\_ T-Shirts (men's sizing) \_\_\_\_\_

Cabin type requested \_\_\_\_\_ Insurance (*highly recommended*) Yes \_\_\_\_\_ No \_\_\_\_\_

Do you need transportation to New Orleans? Yes \_\_\_\_\_ No \_\_\_\_\_ Do you need help with air? \_\_\_\_\_

Passport # \_\_\_\_\_ Expiration Date \_\_\_\_\_ Country \_\_\_\_\_

Passport # \_\_\_\_\_ Expiration Date \_\_\_\_\_ Country \_\_\_\_\_

Credit Card # \_\_\_\_\_ Exp \_\_\_\_\_ Security Code \_\_\_\_\_

Name on Card \_\_\_\_\_ Total Paid \$ \_\_\_\_\_

# PETTICOAT JUNCTION DANCE SHOP



14523 Highway 99 #1  
Lynnwood, WA 98087  
800-344-3262 425-743-9513

[www.petticoatjct.com](http://www.petticoatjct.com)

email us! [friends@petticoatjct.com](mailto:friends@petticoatjct.com)



## TIGER MOUNTAIN



Your *Engraving and Promotions* Source  
for Square Dance and All Activities

Rod & Taj Alex  
206-271-5639  
[rod@tmengraving.com](mailto:rod@tmengraving.com)

[rod@tmengraving.com](mailto:rod@tmengraving.com)



## MEMBERS NEEDING HEAL-IUM



**Les Kilwein - Harbor Haylofters - Sou'Wester Council**

And all of the dancers recovering from Covid-19

## IN MEMORY



**Jim Vorderbrueggen - Appleland Promenaders - (photo in North Central Council)**  
**Lorna Hayden - Cued for several clubs - Blue Mountain Council - September 1.**  
**Frank Trent - Tri-City Circulators & Prairie Shufflers - Blue Mountain Council - July 6.**  
**Carolyn Nelson - Rainbow Squares - Mount Baker Council**

*Honor your dancers with a memorial donation to the Heritage Center.  
Contact Ellen Ostrum (425-308-9559) or Doug Keyes (425-478-3397)  
for more information*

---

This will be a regular page in Footnotes. I hope it's a blank page always! If your club would like to include dancers on this page please send a separate email to [footnotes\\_wa@yahoo.com](mailto:footnotes_wa@yahoo.com). If their names are in the articles only they may be missed when compiling the magazine. A separate email will help ensure they are included so healing thoughts and prayers may be sent their way.



# BLUE MOUNTAIN COUNCIL

**Area Reporter  
Fran Delozier**

[tanklifter@aol.com](mailto:tanklifter@aol.com)

509-460-1340



There is not a **BLUE MOUNTAIN COUNCIL** meeting scheduled at this time.

All **PRAIRIE SHUFFLER** activities are canceled through December 2020. We were saddened to hear of the passing of two of our longtime dancers. Frank Trent danced with the Prairie shufflers and the Tri-City Circulators. Lorna Hayden cued for all the clubs in Blue Mountain Council. They will be missed when we start dancing again.

**PRAIRIE SHUFFLERS**  
Shufflers Shanty  
717 N. Irving, Kennewick

DANCING 1ST & 3RD FRIDAYS  
SEPTEMBER-JUNE  
PLUS 7:00 - 8:00 PM  
MAINSTREAM 8:00 - 10:00 PM  
CHECK OUT OUR AD FOLLOWING THE  
REPORT

See Shuffler ad for dance information

The **MELODY MIXERS** Round Dance club has canceled all dances and lessons through the rest of the fall season, but that will be dependent on the status of the COVID 19 closures and restrictions.

Dancing will certainly be different when we resume. I assume that food and drink may be restricted to personal water bottles. Hand washing or sanitizing will be a must between tips or sets. Will we all be wearing face coverings? Maybe. Probably. I can't figure out a way that we can dance and still comply with Social Distancing – 6 feet strictions are lifted.

Photo by  
Priscilla Davis

The new president, Gary and Suzanne Benefield, will notify the club when dances and lessons will resume. We are hoping we can have our annual New Year's eve dance.

The **MUDDY FROGS**, of Milton-Freewater, are dark until next season or later depending on the "stay at home" orders in Washington and Oregon. However, The Milton-Freewater Muddy Frogs plan to welc. For further information, please call Merri Anne Huber at 541-861-9055.

**TRI CITIES CIRCULATORS** and **FAMILY-A-FAIR** are not meeting for dances or lessons at this time.

**MUDDY FROGS  
SQUARE DANCE CLUB**



**Caller: Guest  
Cuer: Guest**  
3rd Sundays • 2-4 PM  
Milton-Freewater Community Center  
105 NE 5<sup>th</sup> Milton-Freewater, OR  
For info • e-mail:  
[merriannah@charter.net](mailto:merriannah@charter.net)





# BLUE MOUNTAIN COUNCIL DANCE SCHEDULE



**All dances are cancelled until further notice**

## Sunday -

**Muddy Frogs:** Mainstream & Rounds .... 3rd Sunday Year Around

..... Teacher, Merri Anne Huber .....

Milton-Freewater Community Center • 109 NW 5th Milton-Freewater, OR

**Contact:** Merri Anne Huber 541-861-9055 or [merriannah@charter.net](mailto:merriannah@charter.net)

## Tuesday -

**Melody Mixers:** Rounds Ph 2-4 ..... Every Tuesday Year Around

..... Cuer, Bill & Karen Holm

Shuffler's Shanty • 717 N Irving, Kennewick, WA

**Contact:** Karen Holm 509-542-1310 or [bkholm@charter.net](mailto:bkholm@charter.net)

## Thursday -

**Tri-City Circulators:** Plus and Rounds .. Every Thursday Year Around

..... Caller, Jim Swanson

Eagles Lodge #2485 115 Fruitland St. • Kennewick, WA

**Contact:** Thelma Swanson 509-539-2660 or [paintedswan@frontier.com](mailto:paintedswan@frontier.com)

## Friday or Saturday -

**Prairie Shufflers:** Mainstream with Plus and Rounds 1st & 3rd September  
thru July, *(See Prairie Shufflers Ad for dates)*

..... Guest Callers and Cuer, Bill Holm

Shuffler's Shanty 717 N Irving • Kennewick, WA 509-783-4222

**Contact:** Jonnie Jenquin 509-628-0354 or [jenquin.uj@gmail.com](mailto:jenquin.uj@gmail.com)

**Family a-Fair:** Mainstream with Plus and Rounds 2nd & 4th Saturday Year Around

..... Caller, Jim Swanson

Vetrans Memorial Golf Course • 201 E Rees Ave

Walla-Walla WA • 509-525-2870

**Contact:** Thelma Swanson 509-539-2660 or [paintedswan@frontier.com](mailto:paintedswan@frontier.com)

# CENTRAL AREA COUNCIL

*Area Reporter*  
**Carel & Michael Edgerly**  
[carel@centurylink.net](mailto:carel@centurylink.net)



[www.centralareacouncil.org](http://www.centralareacouncil.org)

NO REPORT



Photo by Donna Rohde

## GATESWINGERS

Sept. thru May: 1st & 3rd Saturdays  
1st Saturday Pre-Plus 7:00 PM  
3rd Saturday Pre-Rounds 7:00 PM  
Mainstream 7:30 - 9:30 PM  
*with finger food following the dance*  
4th Fridays Phase II Rounds 7:30-9:30 PM

**Daron Tandberg, Caller,**  
**Cyndi Silicki, Cuer**

Summer Dance -- 4th Saturday in July  
David & Sharon Boggs - Caller & Cuer  
Yakima Square & Round Dance Center  
Moxee, WA Info: (509) 949-6712  
Gateswingers@ Circle 8 Ranch  
2nd Weekend In August



## BLUE AGATE SQUARES

2<sup>nd</sup> & 4<sup>th</sup> Saturday  
7:00 - 9:30 p.m.

Caller- Daron Tandberg  
Cyndi Silicki - Cuer

Swauk-Teaway Grange, Cle Elum  
509-304-4478 or 509-304-8040

## SILHOUETTE DANCERS

*1<sup>st</sup> Thursday Intermediate*

Thurs - Ph 2 + 7:30-8:30 pm some intermediate  
Ph3/4 lessons 6:30-7:30 pm Dance/Workshop 8:30-9:30 pm Cuer:

**DEBBIE & PAUL TAYLOR**

Yakima Square & Round Dance Center -  
207 E Charron Rd - Moxee, WA 98936  
509-965-3015 • Visitors Welcome



*Just go to your local DMV.*

*You can still get your own Square Dance plate!*



[www.cpsc-squaredance.org](http://www.cpsc-squaredance.org)

# CENTRAL PUGET SOUND COUNCIL

**Area Reporter  
Donna & Tom Rohde**

253-833-2825

[donnalou13@comcast.net](mailto:donnalou13@comcast.net)

The **BOOTS & LACES** would like to wish all our square dance family a very Happy Thanksgiving. We are all missing our friends and family as this stay-at-home order continues. We are looking forward to getting back to our normal lives and activities, hopefully, after the first of the year. Please stay safe and healthy.

We are hopefully planning to host the CPSC dance in late January. More information to follow as the time gets closer and the stay home order is lifted.

We miss all of you!!!

*Pat Hoot*

[hootpnr@yahoo.com](mailto:hootpnr@yahoo.com)

All activities for November have been cancelled due to restrictions placed upon Cedar Valley Grange where the **JET STEPPERS** dance in Maple Valley.

*Dave Smith*

[daves787@comcast.net](mailto:daves787@comcast.net)

The **PI-R SQUARES** wish we were dancing, but nothing until January 9th and not positive on that date. We hope they will let us get back to dancing. We did a get-together at our house in September with about 17 dancers attending. They brought their own food and drinks and were able to stay 6-feet apart most of the time and were wearing masks.

**Pi-R-Squares  
Dance Club**  
**2nd & 4th Saturday**  
@ Meridian Grange 15422 SE 272nd St Kent, WA  
7:30-10pm MAINSTREAM  
Come early for our 7-7:30pm:  
PLUS Dance—Sept 8th  
ROUND Dance Teach—Sept 22nd  
Caller: Andy Garboden  
Cuer: Kyle Quande  
CHECK OUT OUR NEW WEBSITE: [WWW.PI-R-SQUARES.ORG](http://WWW.PI-R-SQUARES.ORG)

We did some square dancing on the deck with Andy Garboden calling and all were wearing masks. We used Styrofoam pipe wrap sticks about 9 inches long and touched sticks instead of touching hands. We were not able to stay 6 feet apart. It was not quite as much fun as touching hands, but it was still a fun thing to do on a very nice day.

I was able to go fishing in Ketchikan, Alaska in September and it was a fun adventure. Five of us caught 109 Coho Salmon and the weather and fishing were great. Marilyn and I celebrated our 58th Anniversary in

September, if you call going out to Applebee's a celebration, but with the virus, it is okay.

Happy Veterans Day and have a great Thanksgiving and come dance with the Pi-R Squares with Andy Garboden and Kyle Quande any 2nd or 4th Saturday at the Meridian Grange in Kent whenever we are allowed to dance again.

*Terry & Marilyn Quinnett*

[mvjunkdealer@juno.com](mailto:mvjunkdealer@juno.com)



Square and Round dancing may be on hold, but the friendships and camaraderie these wonderful activities have afforded us continue on at **WAGON WHEELS**. “Circling the Wagons” is one of our Club’s way of keeping in contact with our dancing friends. In the past couple of months, Club members have circled up in the parking lot of the Kent Meridian Grange bringing lawn chairs and snacks to enjoy in each other’s company. It was so great to see everyone, catch up on club member’s lives with Covid-19 restrictions and to be reminded of how important these friendships are.

What was most interesting was to find out what club members have been doing in these difficult times and most are on their feet and active. Many have been doing home projects, tackling the chores on which they have been procrastinating for years, like cleaning out the garage or the basement. Others have spent more time in their yards, gardening and growing food and flowers. Some have been busy crafting all types of projects, from wood carving art to quilting. Many have been traveling and getting out into the great outdoors for hikes and bike riding. The spirit of the round and square dancer is alive and well at Wagon Wheels.

Donna Rohde, Club “Wagon Tracks” Newsletter Editor has been keeping members informed and used this downtime to publish pictures from our past that remind us of the fun we have all had and to keep the flame of friendship burning. In upcoming issues, Donna will publish pictures of member’s garden successes for all to admire and inspire.

One thing we all can do is to make a few phone calls to

dancing friends. Some may not be able to get out or are fearful to do so, so letting them know they are thought of may go a long way to help them right now. In this topsy-turvy world in which we now live, Wagon Wheel members continue to make the best of a tough situation and look forward to the days when we are all circling up on the dance floor instead of a parking lot, even though that is fun too. Never has the saying “keep on keeping on” had more relevance. So, let’s do that until we meet again on the dance floor! Be well and know that “This Too Shall Pass.”

Geri Kraft, [pinefox@comcast.net](mailto:pinefox@comcast.net)

*Donna Rohde  
CPSC Area Reporter  
Central Puget Sound Council*



**CLUBS OF  
CENTRAL PUGET SOUND COUNCIL**



**JACKS & JILLS - KENT**

Caller: Brett Kappenman  
Cuer: Kyle Quande  
Every Sunday - Meridian Grange  
6:00 - 8:30 pm - Teen Club - M/S

**BOOTS & LACES - TRAVELING CLUB**

If you are having a Special Dance, Anniversary, Fundraiser, Dinner, etc. contact us so we can plan on coming to support your dance.

**RON & PAT HOOT - 206-784-9796**  
**hootpnr@yahoo.com**

**PI-R SQUARES - KENT**

Caller: Andy Garboden  
Cuer: Kyle Quande  
2nd & 4th Sat - Meridian Grange  
2nd Sat - 7:00 RD W/S or Teach  
4th Sat - 7:00 - "Plus" Dance  
7:30 - 10:00 - Mainstream Dance

**JET STEPPERS - MAPLE VALLEY**

Caller: Chuck Martin  
Cuer: Rochelle Catt  
1st & 3rd Saturday - Cedar Grange  
1st Sat - 7:00 - Round Dance W/S  
3rd Sat - 7:00 - Square Dance W/S  
7:30 - 9:30 - Mainstream Dance

**WAGON WHEEL SQUARES**

Caller: Scott Coon / Stephen Cole  
Cuer: Lorraine & John Rouse  
1st & 3rd Sat - Meridian Grange  
1st Sat - 7:00 - "Plus" Dance  
3rd Sat - 7:00 - Round Dance W/S  
7:30 to 10:00 - M/S & 1 Plus Tip

**No "October Dances" Due to the Corona Virus Pandemic**

**FEDERATION TRAVEL CLUB**



**We would love to come  
dance with you - *Give us a call -***

- **Poulsbo Promenaders, Peninsula Council** •  
**206-842-5147**





[www.sqdance.com](http://www.sqdance.com)

# EVERGREEN COUNCIL

*Area Reporter*  
**Colleen Relyea**

360-600-1804

[embroiderybycolleen@yahoo.com](mailto:embroiderybycolleen@yahoo.com)

## Buzzin' Bees

### MS Square Dance Club

1<sup>st</sup> & 3<sup>rd</sup> Sat. at Hazel Dell Grange

Pre-Rounds at 7:00

MS & 3<sup>rd</sup> tip Plus 7:30

7509 NE Hazel Dell Ave.

Vancouver, WA 98665

Caller: K.C. Curtis

Cuer: Guest

Questions? (360) 903-2139



**H**oliday season 2020 will be memorable. How resilient, how hopeful and kind,, how considerate and compassionate, and how we include and care for others will be the legacy of our own choosing. R Square D wishes blessings for all our dancing friends and peace for your hearts this holiday season 2020.

Most sincerely,

*Annie Tietze*  
*R Square D*

After this November issue I will not be reporting regularly, unless something comes up worthy of interest. Difficult for you, I realize. This too shall pass, what to is the question.

Blessings to your holiday season.

*Annie*



## First & Third Saturday

Washington Grange #82  
7701 NE Ward Road.  
Vancouver, WA

PLUS CLUB

**JIM HATTRICK**  
caller/cuer

[jimandjudyhattrick@gmail.com](mailto:jimandjudyhattrick@gmail.com)

[www.happy-hoppers.com](http://www.happy-hoppers.com)

**Info: 360-573-5886**



## R SQUARE D

Craig Abercrombie, Caller  
Lonnie Sycks, Cuer

2nd Friday & 4th Sat (Sept-May)  
2nd & 4th Wed (June-Aug)

Plus 7:00-8:00; Mainstream 8:00-9:30

Annual Octoberfest  
2nd Weekend in October

Kelso Senior Center  
106 NW 8th Ave, Kelso, WA

360.749.3964 (Dick)  
[www.r-square-d.info](http://www.r-square-d.info)

## Columbia River Dancers

2nd & 4th Saturdays

Hazel Dell Grange

Vancouver, WA

7-8 Plus 8-10 Mainstream

Lessons Tuesdays @ 7PM

Jim Hattrick & Guest Callers

Q's 360-606-8849



# MOUNT BAKER COUNCIL

*Area Reporter*  
**Ronald A. Ward**

[ron.ward740@gmail.com](mailto:ron.ward740@gmail.com)



[www.sqdance.org](http://www.sqdance.org)

The following clubs from the **MT. BAKER COUNCIL** wish to connect and maintain solidarity with all our dancing friends from other councils within the State of Washington. We know it is discouraging not to be able to dance month after month. But we remain hopeful and are planning carefully now so that we will be ready to reopen as soon as possible. We also are looking forward to the 2021 State Square Dance Festival, to be held June 17-19, and want to encourage everyone to both register for the Festival and to make reservations for a room at the Delta Hotel by Marriott in Everett, WA.

*Ronald A. Ward*  
[ron.ward740@gmail.com](mailto:ron.ward740@gmail.com)

The **STANWOOD SASHAYERS** hope that our November's greetings to all of our friends and dancers find you enjoying the holidays, staying safe and secure from this pandemic, and healthy.

The Sashayers will not be dancing until the pandemic is over and our Governor opens the lockdown on gatherings. We hope to see you on a dance floor soon.

*Lonny Graff*  
[blgj@wwdb.org](mailto:blgj@wwdb.org)

The **HAPPY HOPPERS** held a socially-distanced version of our summer picnic this year. A small group of stalwarts and COVID-19 survivors attended. We missed all those who could not attend and hope to see everyone on the dance floor someday soon. We are looking forward to dancing at Circle 8 again in summer 2021.

In September, we had our second (third? Who can keep track these days?) Zoom meeting. Though technologically challenging, it was good to see all those who attended. If this lasts much longer, all of our houses and gardens will be award worthy. We look forward to neglecting housework again in favor of going dancing!

Get a head start on 2021: register for the Tons of Fun in 2021 Washington State Square Dance Festival. Book your reservation for a room at the Delta Hotel in Everett today. It lets the hotel know that you support the Festival and costs nothing until check in.

*Melody Scalzo*  
[melscalz@yahoo.com](mailto:melscalz@yahoo.com)



We are sorry to let you know of the passing of one of our beloved members, Carolyn Nelson, of the **RAINBOW SQUARES** and Ten Mile Grange. She was involved with Rainbow Squares, helping at the dances and at lessons, and was our Decorating Chairman for many years. She also was the Decorating Chairman for the "Duck Through the Door in 2004" Washington State Festival in Lynden. She designed many of the "Grange Booth" displays at the NW Washington Fair in Lynden, for Ten Mile Grange, and she was an exceptionally talented artist. We will miss her smiling face and friendship.

As reported earlier, Rainbow Squares has cancelled their dances and caravans until after January 2021. However, many of our members are enjoying dancing to Brent and other Callers via Zoom. The Zoom dances involve dancing with "Ghost" couples in your own living room and can be very interesting. (I have found that the "Ghost" dancers goof up quite frequently!)

It is very nice to be able to continue dancing and brush up on our skills while staying home. Thank you to all the Callers who offer the Zoom dances! We hope to see you on the dance floor soon! Stay safe.

*Lew Gaskill*  
[olgaskill@comcast.net](mailto:olgaskill@comcast.net)

**FERN BLUFF SQUARES** have canceled dancing through December. We dance and teach at two different halls, both being closed. We are waiting to hear that the state may move to Phase Four. A number of our members contracted the corona virus in the early stages, all have returned to health.

Stay safe. We will get past this.

*John Dow, President*  
[johndd1946@outlook.com](mailto:johndd1946@outlook.com)

At this time, **HAPPY ROUNDERS** is not planning any dances in November.

*Larry Mercer, President*  
[larry\\_mercer@hotmail.com](mailto:larry_mercer@hotmail.com)



At **SKY VALLEY WHIRLWINDS**, we are anxiously awaiting the return of dancing. We really want to show off our dance venue. We have even painted the inside of the coat closet!

We are still planning to have our first dance on January 16th. We will, of course, be following the State Federation's recommendations for a safe return to dancing. Lessons are scheduled to start in January, as well. Cross your fingers.

Hope you are well and continue to stay that way. Please follow the guidelines and wear your masks!

*Sandi Moore, President*  
[sandi.moore1950@gmail.com](mailto:sandi.moore1950@gmail.com)

The **SAMENA SQUARES** have hunkered down, following the guidelines set by our Governor. It is the wish of all that we could start dancing soon. However, with the numbers going up and the strict rules, it does not look like that will happen for quite some time.

That being said, all our members hope everyone has a wonderful Thanksgiving. Even though we are inconvenienced and probably going stir crazy looking for a place to escape, we all have so much to be thankful for. God bless you all!

*Cynthia Kemp, President*  
[samenapres@gmail.com](mailto:samenapres@gmail.com)

The **DUDES & DOLLS'** annual campout, however, with some careful planning proceeded to occur on the first weekend of August. All of our activities were held outdoors. We held a silent auction with items displayed on tables all around the camping area, raising more than \$1,300.00; an RC road race; bicycle races; several potlucks all served cafeteria style; a wine tasting event; and a karaoke session. We had ten rigs and individuals participating each day while staying in local hotels so it was a fun group, and despite the crisis we had a great safe campout experience.

Our plans were dashed when we had to cancel our annual club picnic, which was to be held in the parking lot of the Cedar Valley Grange where we normally dance. We still don't know when we will be able to resume our normal schedule of dancing, but based on the recommendations of our State Dance Federation, we are cancelling all club dance activities through the end of the year. Resumption of dancing will depend on the Phase Recovery Level of Snohomish County. We will review Snohomish County's progress on Recovery Level and update our plans toward the end of the year, where we will hopefully be planning some dances for the New Year. Hope to see you on the dance floor soon.....

*Robert Reichle and Vicki Lieske*  
[robert\\_r\\_r52@yahoo.com](mailto:robert_r_r52@yahoo.com)

The **FREEWHEELERS** continue to evaluate current information from health officials and our governor, and we will stay on the path we discussed at our zoom meeting in August. Our next zoom meeting will be in November. All of our dances have been cancelled until 2021. We hope we can get back to dancing in the New Year. Please wear your masks and continue social distancing. Virtual yellow rocks to all of our fellow square and round dancers and stay safe!

*Ruth Jester*  
[ruthjester@frontier.com](mailto:ruthjester@frontier.com)

The **SQUARE CROWS** are still on hold right now hoping that this pandemic relents soon. We are looking forward to 2021 when we'll be able to start again. We did get word that the Governor's office has said social dancing will not be permitted even in Phase 4. There will be another Zoom meeting with MB Teachers, Callers & Cuers on Nov. 9. If you are interested in participating, contact your club president for information. There will also be a State Federation meeting on Oct. 9 and 10 where these topics and more will be discussed. Hang in there everyone!

*Lynn Von Seggern*  
[lynnvonseggern@gmail.com](mailto:lynnvonseggern@gmail.com)

The **WHIRLYBIRDS** hope everyone is staying safe and being careful. The club president hosted a zoom meeting on 10/10 and based on the success of the meeting, the club has decided to continue doing zoom meetings with their members on the second Saturday of every month. We hope you have a good Thanksgiving and continue to stay safe.  
[karlinha8@yahoo.com](mailto:karlinha8@yahoo.com)

Hugs,  
(\\_/)  
(=,=)  
(\*)\_(")

*Karla Boehme*

The **FIDALGO FOGCUTTERS** held a Board Meeting on September 29 at which they voted to cancel all dances from November 2020 through January 2021. This action was taken partly because of the recommendation of the State Federation, but also in recognition of the need for lead time to return to dancing. The Club also voted to donate \$500 to the Skagit Valley Grange as support during this difficult year. It was also announced that the New Year's Eve dance, normally sponsored by four Mt. Baker Council clubs, would not be held this December. On a more positive note, the Club encouraged its members to register for the 2021 State Festival and to make reservations at the Delta Hotel by Marriott in Everett, WA June 17-19, 2021.

*Ronald A. Ward*  
[ron.ward740@gmail.com](mailto:ron.ward740@gmail.com)

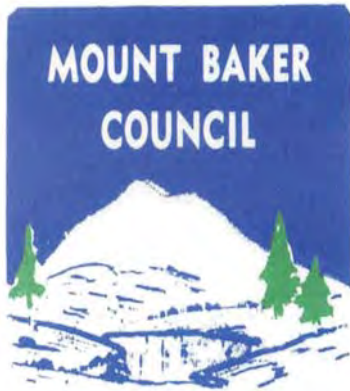

**Council Website**     [www.sqdance.org](http://www.sqdance.org)  
**State Website**        [www.squaredance-wa.org](http://www.squaredance-wa.org)  
 See Washington State Square Dance Directory for hall addresses

**Council information:** Council President     Doug Keyes     425 478-3397  
 Council Meeting     1st Wednesday - September thru June  
 Marysville School District - Board Room     7:30-9:30 PM  
 4220 80<sup>th</sup> St NE  
 Marysville, WA

- A BLAST** / A1-A2 / 1st & 3rd Saturdays (Check Council Website)- 11:00 AM-1:30 PM  
 Cedar Valley Grange, Lynnwood     Guest Callers & Cuers     206 369-7131
- CASCADE CROSSFIRES** / Plus / Mondays - 6:30-9:00 PM  
 Cedar Valley Grange, Lynnwood     Susan Morris & Guest Callers     425 739-6096
- DANCING SHADOWS** / Rounds / Phases 3, 4, 5 / 1st & 3rd Sundays - 12:30, 2:15, 4 PM  
 Juanita Community Club, Kirkland     Debbie Taylor     206 362-3734
- DUDES AND DOLLS** / Mainstream / 2nd, 4th, some 5th Friday - 7:00-10:30 PM  
 Cedar Valley Grange, Lynnwood     Scott Coon/Debbie Taylor     425 308-3950
- FERN BLUFF SQUARES** / Mainstream / Family, 2nd Saturday - 7:30-10:30 PM  
 South Lake Stevens Grange, Lake Stevens     Robert Sax/Karen Neverdowski     360 926-6673
- FIDALGO FOGCUTTERS** / Plus / 3rd Friday - 7:00-10:00 PM  
 Skagit Valley Grange, Sedro-Woolley     Guest Callers/Bob Berka     360 682-5348
- FREEWHEELERS** / Mainstream / 1st & 3rd and some 5th Sundays - 7:00-10:00 PM  
 Cedar Valley Grange, Lynnwood     Roger Spiese/Debbie Taylor     206 367-9219
- HAPPY HOPPERS** / Mainstream / 2nd & 4th Sundays 6:00- 9:00 PM  
 The Hayloft, Lynnwood     Guest Callers/Guest Cuers     425 238-7870
- HAPPY ROUNDERS** / Rounds / Phase 3 & 4, Tuesday - 7:30-9:30 PM  
 The Hayloft, Lynnwood     Randy Preskitt     206 365-8095
- MT BAKER TEACHERS, CALLERS & CUERS**     Information: Steven Cole  
 stephen@isquaredance.com     206 769-4959
- RAINBOW SQUARES** / Mainstream / 2nd & 4th Saturday - 7:00-9:30 PM  
 Ten Mile Grange, Lynden     Brent Mawdsley     360 961-6170
- SAMENA SQUARES** / Mainstream / 2nd & 4th Friday - 7:30-10:00 PM  
 Juanita Community Club, Kirkland     Guest Callers/Cuers     425 686-2488
- SKAGIT SQUARES** / Mainstream / 3rd Saturday - 7:30-10:00 PM  
 Mount Vernon Senior Center, Mount Vernon     John Corrigan/Bob Berka     360 630-3370
- SKY VALLEY WHIRLWINDS** / Mainstream, 3rd Saturday - 7:30-10:30 PM  
 Tri-way Grange, Mill Creek     Guest Callers/Karen Neverdowski     360 805-1902
- SQUARE CROWS** / Mainstream / 3rd Friday - 7:30-10:00 PM  
 Maltby Community Center, Maltby     Guest Callers/Karen Neverdowski     206 914-2253
- STANWOOD SASHAYERS** / Mainstream, 1st Sat - 7:30-10:00 PM  
 Stillaguamish Grange Hall, Stanwood     Eddie Harry/Bob Berka     206 383-4977
- WHIRLYBIRDS** / Mainstream / 1st Friday (Floor Level) & 2nd Saturday - 7:30-10:30 PM  
 The Hayloft, Lynnwood     Dave Harry/Roxanne Boelter     206 687-3308

REV 9/2020

4 x 8's

Hello all;  
Let's start by saying the recommendations from Washington State Square and Round dance association begin with "Canceling all dances for 2020". This, of course, aligns with State and Federal rules regarding Covid compliance. As many already know, Grant County requires that we be in Phase 4 before we can begin dancing.

Having cleared this up, we can start thinking about 2021 Wearing masks when entering and leaving the building will be required, hand sanitizer stations will be needed, NO FOOD or drinks unless, you can bring your own, NO SHARING and take it home when you leave. Signing in for ALL entering will be mandatory which must include phone numbers for all, including guests dancing or not.

This is just a start, we currently have no direction from the Moses Lake Senior Center, and it is likely that they may have additional restrictions.

I wish there was more dance news but as above, no one is dancing. A few states here and there are dancing but so far I've not heard of any that are near us, SAD to report, missing out on my favorite activity.

The good news is, to my knowledge, we have NO REPORTS for Covid in our area!

*Happy feet,  
Jack Roberts*

Since all our dances are cancelled, the **APPLELAND PROMEADERS** would like to feature caller, Tom Clymer and his wife, Chris, this month. Tom grew up in the Wenatchee area and after graduating from high school joined the navy in December of 1966. He made 4 trips to Vietnam and was honorably discharged in 1972. While going to school at Central in Ellensburg his sister and brother-in-law forced him (as he put it) into square dancing. Tom has been calling since 1975. Tom met his wife, Chris, at the Blue Grass Swingers. They have been together about 38 years and married for 28 years. Tom has two daughters- one who is the mayor of East Wenatchee and the other daughter who lives in Texas. Tom started the Plus Bunch club around 1977. They originally danced in a basement, then moved to a barn, and eventually to the

East Wenatchee Grange. Tom has been teaching lessons for the Appleland Promenaders for many years and has been a member of CallerLab since 1980. Tom has been teaching Plus in a Week along with Kevin Thomier at Circle 8 for 11 years. Tom and Chris enjoy spending most summer weekends at Circle 8 with their two dogs, Edgar and Allie.

Loss of a Member: (See Jim's photo on the next page)

James Samuel "Jim" Vorderbrueggen, 78, a resident of Dryden, WA, since 1987, went home to be with his Lord on Monday, September 7, 2020. He was born on May 13, 1942, in Lacrosse, WA. He is survived by his wife of 31 years, Barbara. Jim and Barb were very active in the Appleland Promenaders club. They were chairman of the Apple Blossom weekend for 2 years. They also served as East Wenatchee Grange board members. Jim had a 39-year-long career as a Signal Maintainer with the Great Northern Railroad, which eventually became the BNSF Railroad. He was an avid hunter and enjoyed camping. Cremation has taken place and Jim's life will be celebrated in the spring of 2021.

*Connie Mulholland*

## Wheatland Whirlers

As we sit and twitter our thumbs, we need to think of the positive things we have going on in our lives. The weather has been unbelievable, late Spring weather in October enabling us to get things accomplished both inside and outside our homes. For those of us that need to socialize, we can find volunteer things to do where we can wear our masks and social distance. For me, besides shopping, I'm volunteering at our Senior Thrift Store. I work outside so don't mingle with the customers and we all wear masks and mostly social distance. As for square dancing, I miss it very much and still have no idea as to when we'll be able to get back to the activity we all love. I do have one dance scheduled for next year (not written in gold) and that's our 69th anniversary which will be the 2nd Sat. in April, 2021. I'm almost afraid to say who we have scheduled to call and cue for it as it might get jinxed. So for now, please stay healthy, wear masks and let us do our part to help avoid the virus from continuing.

*Judy Shock*

# The Clubs of North Central Council



## **Appleland Promenaders – Mainstream**

www.applelandpromenaders.com

1<sup>st</sup> Friday, 2<sup>nd</sup> & 4<sup>th</sup> Saturday

East Wenatchee Grange • 3400 Sunset Hwy., East Wenatchee

*Info:* Bob & Connie Mulholland - 509-881-4961

or [sqdnrc@nwi.net](mailto:sqdnrc@nwi.net)

## **Buds & Blossoms – Mixed Level**

2<sup>nd</sup> Friday; 1<sup>st</sup> & 3<sup>rd</sup> Saturday

East Wenatchee Grange • 3400 Sunset Hwy., East Wenatchee

*Info:* Don Jackson - 509-670-3540

or [imt655@hotmail.com](mailto:imt655@hotmail.com)

## **Cascade Twirlers – Mainstream**

1<sup>st</sup> & 3<sup>rd</sup> Saturday

East Wenatchee Grange • 3400 Sunset Hwy., East Wenatchee

*Info:* Randy & Sheila Ogle - 509-663-2395

## **Moses Lake 4x8's – Mainstream**

1<sup>st</sup> & 3<sup>rd</sup> Saturday

Moses Lake Senior Center • 608 E. 3rd Ave., Moses Lake

*Info:* Del & Jackie Chase - 509-764-4254

or [deljackiechase@nctv.com](mailto:deljackiechase@nctv.com)

## **Plus Bunch – Plus Level**

Every Wednesday

East Wenatchee Grange • 3400 Sunset Hwy., East Wenatchee

*Info:* Tom & Chris Clymer - 509-293-3516

or [Tom.Clymer@charter.net](mailto:Tom.Clymer@charter.net)

## **Wheatland Whirlers – Mainstream •**

2<sup>nd</sup> Saturday; Sept.-Dec. 2<sup>nd</sup> & 4<sup>th</sup> Saturday; Jan.- June

Ephrata Senior Center • 124 C Street NW, Ephrata

*Info:* Judy & Harold Schock - 509-754-4803

or [jaschock@homenetnw.net](mailto:jaschock@homenetnw.net)

**ALL CLUBS DANCE SEPTEMBER THROUGH MAY  
WITH SOME SUMMER DANCES.**



# **NORTH OLYMPIC COUNCIL**

*Area Reporter*

**Trish Gaine**

360-683-2409

*fasolard@olympen.com*





# PENINSULA COUNCIL

Area Reporter  
 Kitty & Paul Ogg  
 360-692-6032

[kjoggpr@aol.com](mailto:kjoggpr@aol.com)

A request for some humor from Kitty Ogg

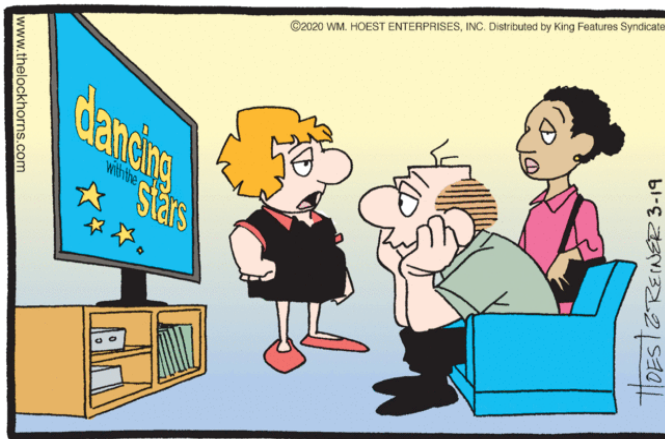

"LEROY IS PATIENTLY WAITING FOR THEM TO FEATURE POLE DANCERS."



"I VOTE FOR PRESIDENT ... LEROY VOTES FOR THE PRETTIEST FIRST LADY."



Dancers, Callers, Cuers, Clubs  
 Please visit and use the Washington  
 Federation Web Site often

<http://www.squaredance-wa.org>

Send lesson information  
 immediately to:

Webmaster, Dick Beham  
[webmaster@quaredance-wa.org](mailto:webmaster@quaredance-wa.org)

**The Clubs of Peninsula Council - 6800 W. Belfair Valley Rd, Bremerton  
Kitsap Square Dance Center in Gorst – kitsapsquaredance.com**

<b>DUDES AND DOLLS</b>	<b>SQUARE STEPPERS</b>
Mondays from 2nd Monday in Sept to 2nd Monday in June	2nd Saturday each month
Plus Dancing – 1-3PM	Plus Dancing – 7:30 - 10PM
Kitsap Square Dance Center, Gorst	Kitsap Square Dance Center, Gorst
Caller: Don Smith filling in for Willie Sewell	<b>GUEST CALLERS</b>
<i>More info call: Russ Richardson – 360-373-1822</i>	<i>Caravans/Mystery Trips/Camping</i>
	<i>More info call: 360-377-9494</i>
<b>GIG HARBOR TWIRLERS</b>	<b>KITSAP SQUARE DANCE CENTER</b>
1st Saturday each month except	Gorst (Bremerton)
1st & 3rd in January & 3rd Saturday in September	RV Camping; \$15.00 per Night
7:30-8PM Plus – 8-10PM Mainstream	For Square Dancers
Lessons, Student Level Dance, Mainstream & Rounds	Water & Electric Available
Caller: Roger Spiese, Cuers Carolyn & Larry Small	<i>Come Dance the Gig Harbor Twirlers, ,</i>
Kitsap Square Dance Center, Gorst	<i>Paws &amp; Taws , Dudes &amp; Dolls Plus,</i>
<i>More info call: 360-692-3723</i>	<i>Rounds Squares &amp; Square Steppers Plus</i>
<b>ROUND SQUARES</b>	<b>PAW AND TAWS</b>
4th Saturday, 3rd Saturday December only	1st & 3rd Fri. September-June except March, 1st Fri. & 3rd Sat.
7:30-8PM Plus; 8-10PM Mainstream, Rounds	3rd Saturday only in July & August
Guest Callers	7:30-10PM Mainstream, Rounds, Plus Tip
Cuer: Joyce Sebree	Caller: Roger Spiese, Cuer, Shawn (Wendy) Cavness
Kitsap Square Dance Center, Gorst	Kitsap Square Dance Center, Gorst
Caravans-Mystery Trips-Camping \$15.00 per Night	<i>Caravans-Mystery Trips-All Dancers Welcome</i>
<i>More info call: 360-307-8460</i>	<i>More info call: 360-930-5277</i>
<b>SWEETHEART ROUNDS</b>	
Lessons Thursdays 7:00-9:00 PM	
Dances on 2nd Fridays 7:00-10:00	
Cuer- Shawn Cavness	
Kitsap Square Dance Center, Gorst	



**"I ALWAYS KEEP A BURNT ROAST IN THE FREEZER  
IN CASE I FEEL LIKE EATING OUT."**



<https://www.squaredance-rainier.org>

# RAINIER COUNCIL

**Area Reporter  
Lane Johnston**

253-200-4566

[lanej@chessmenkastle.com](mailto:lanej@chessmenkastle.com)

**R**AINIER COUNCIL continues (like every other council) to wish for an end to the “Drought” (actually, the Covid-19 pandemic is much worse than a drought, but you get the picture). The devastating effects of past several months will be felt for some time by every dancer and by every club in our Federation, as well as within our council! One Rainier Council club succumbed recently...the South Sound Squares, (formerly known as South Sound Singles), a club with a decades-long history, has officially announced it has folded. As far as we know, the remaining clubs within the Rainier Council will weather the current crisis.

One ray of “sunshine” --- a Zoom-style get-together takes place on the third Saturday of each month and all Rainier Council dancers are invited to attend. Log-in information is available in the Announcements section of the Rainier Council Facebook group and page. We are not allowed to dance presently, but that doesn’t stop us from being able to “see” one another!

*Lane Johnston,  
[lanej@chessmenkastle.com](mailto:lanej@chessmenkastle.com)*

The **BONNEY LADS ‘N’ LASSIES**, a mainstream club, looks forward to our return to dancing at some point in

**BONNEY LADS ‘N’ LASSIES**  
Mainstream, Plus Tip  
2<sup>nd</sup> & 4<sup>th</sup> Sat Sep - Jun, 2<sup>nd</sup> Sat Jul & Aug  
Pre-rds 7:00 - 8 MS w/+ tip 7:30 - 10:30 PM  
**GREG WEBER, Caller**  
**LORRAINE ROUSE, Cuer**  
Collins Grange 3404 - 120th St E Tacoma

2021. In the meantime, many of us are joining one another in an on-line video social gathering via Zoom on the second Saturday of each month at our normal dance time, 7:00 pm. And some of us are also joining in the all-Rainier Council video social gathering via Zoom on the third Saturday of each month, also at 7:00 pm. At least we can stay in touch with one another. Login information for the Rainier Council’s Zoom sessions is available on the Rainier Council’s facebook page (if you remember that Roamin’ Tacomans dance in Sumner).

*Sandy Anderson,  
[sandy@pobox.com](mailto:sandy@pobox.com)*

The **SWINGNUTS** dance(d) at the Sumner VFW Hall, 1705 Willow Street. Currently, due to the Covid-19

pandemic, we are not dancing. We hope to return to the VFW Hall once the restrictions that prevent square dancing in the state of Washington are lifted.



We will keep you posted when the Swingnuts, with Caller Don Wood and Cuer Marie Wood, can start dancing again.

We miss all our square dance friends! We’re looking forward to kicking up our heels on the dance floor...the sooner the better!

*Gail Johnston,  
[gailj@chessmenkastle.com](mailto:gailj@chessmenkastle.com)*

The **ROAMIN TACOMANS** hope everyone is doing well and staying safe through the pandemic, fires, smoke,

**Roamin’ Tacomans**  
  
Caller/Cuer: Tom Tomlinson  
We are not currently dancing  
Please check [Wheresthedance.com](http://Wheresthedance.com)  
or call Sharon Herman at 206-510-1984 to find out when & where our next dance will be

etc. We have missed dancing and seeing everyone the last few months. Hopefully we will all be able to get together and be back to dancing after the first of the year. We just have to have fewer cases of Covid. Stay safe. We miss you!

*Sharon Herman,  
[tonysharp@yahoo.com](mailto:tonysharp@yahoo.com)*

I’d love to say that **YOUNG BUNCH** has been busy organizing dances, competition prep or some sort of fun activity but unfortunately, we have not. I personally check in with some of the kids on a weekly or monthly basis, especially when school started. Our kids are struggling,



they miss their friends and they miss dancing, which is so hard for us to believe (hahaha). Normally our kids are on the break of feeling overwhelmed with school and dance activities but now they miss it and we miss them. The Young Bunch board has put off planning any dances or activities until January (at the earliest), but we know that may be extended. We are all looking forward to dancing again, and we all may need a refresher and/or lessons. Maybe this will create some excitement to bring our dance community together once again! We may be 'small' in numbers but when we come together as 'one', we'll be MIGHTY.

*Stephanie Schaeve*  
[sschaewe@gmail.com](mailto:sschaewe@gmail.com)

The **SPINNERS** want to say that we miss everyone and hope you are in good spirits and ready to dance again. The Spinners are not dancing until the Health Department has declared the risk low enough allowing us to resume our dancing.

*Neil Andrews,*  
[neilc42@yahoo.com](mailto:neilc42@yahoo.com)

**EVERGREEN ROUNDS** (no report for this issue) is a Round Dance club, and dances in Puyallup, WA at the Sans Souci Mobile Home Estates Club House. Tom Tomlinson is the cuer/instructor.

*Lu Simmons*  
[simmlu@yahoo.com](mailto:simmlu@yahoo.com)

**SOUTH SOUND SQUARES**...gone but not forgotten!

**ROUSE-A-ROUNDS** (no report for this issue) is a round dance club that dances at Collins Grange, 3404 120th St E, Tacoma, WA. **Lorraine and John Rouse** teach and lead the club.

*Club Reporter position is vacant*

Other Rainier Council clubs/organizations include:  
**NORTHWEST CALLERS ASSOCIATION**





# Rainier Council Clubs

Website: [squaredance-rainier.org](http://squaredance-rainier.org)  
 (check Calendar link for latest info.)

**ALERT: DUE TO THE COVID-19 PANDEMIC, CLUBS ARE NOT DANCING UNTIL FURTHER NOTICE !**

## MONDAY

Every	<b>ROUSE-A-ROUNDS</b> Lorraine & John Rouse	Collins Grange (East Tacoma, WA) 6:30 Beginners, 8-9:30 Ph2/EZ3 Dance 4 <sup>th</sup> Monday, 7-10 (253) 846-8203
-------	--	--

## WEDNESDAY

Every	<b>EVERGREEN ROUNDS</b> Cuer: Tom Tomlinson	Sans Souci Estates (Puyallup, WA) 6:30-8 Teach, 8-9 Ph2-3, 9-10 Ph4-5 (253) 906-9949 or (253) 229-9443
-------	--	--

## FRIDAY

1 <sup>st</sup>	<b>SPINNERS</b> (Mainstream) Caller: Greg Weber Cuer: Sue Weber	Buckley Hall (Buckley WA) 7:00 Pre-Rnds, 7:30-10 MS/Rnds/+Tip (360) 829-0251
2 <sup>nd</sup>	<b>YOUNG BUNCH</b> (Mainstream) Caller: TBA Cuer: Sue Weber	Collins Grange (East Tacoma, WA) 7:00 Pre-Rounds, 7:30-10 MS/Rounds (206) 240-2624

## SATURDAYS

1 <sup>st</sup>	<b>SWINGNUTS</b> (Mainstream) Caller: Don Wood Cuer: Marie Wood	Sumner Valley VFW Hall (Sumner, WA) 7:00 Pre-Plus/Rnd, 8-10 MS/Rnds/+Tip (253) 200-4566
-----------------	---	---

1 <sup>st</sup>	<b>NW CALLER ASSOCIATION</b>	Cedar Grange (Maple Valley, WA) Monthly Meeting, Dances TBA (253) 445-4691
-----------------	------------------------------	--

3 <sup>rd</sup>	<b>SOUTH SOUND SQUARES*</b> *No longer dancing ("folded" in 2020)	
-----------------	--	--

2 <sup>nd</sup> & 4 <sup>th</sup>	<b>BONNEY LADS 'N' LASSIES</b> (Mainstream) Greg Weber/Lorraine Rouse	Collins Grange (East Tacoma, WA) 7:00 Pre-Rnds, 7:30-10 MS/Rnds/+Tip (253) 875-5380
-----------------------------------	--	---

2 <sup>nd</sup> (&/or) 4 <sup>th</sup> Varies...check WheresTheDance	<b>ROAMIN' TACOMANS</b> (Plus) Tom Tomlinson	Sumner Valley VFW Hall (Sumner, WA) 7:30 Pre-Rounds, 8-10 Plus/Rounds (253) 848-7073
--	---	--



# SOU'WESTER COUNCIL

Area Reporter

Don & Judy Wilson

[donjudywilson22@gmail.com](mailto:donjudywilson22@gmail.com)

SOU'WESTER COUNCIL wish we were dancing as usual in 2020, but since we aren't, we wish you a happy Thanksgiving and we hope 2021 we will be back dancing better than ever. In the meantime, stay safe and be patient. This too shall pass.

HARBOR HAYLOFTERS are doing good. Les Kilwien had a spinal stimulator implant put it and seems to be working well for him. Everybody is keeping their distance. We miss you all and hope some time we will all be together again.

## HARBOR HAYLOFTERS

2nd Saturday monthly

Caller: Randy & Chris Carlson

Pre Rounds 7:00

Ms Dance 8 - 10:00

BRAND NEW LOCATION

ABERDEEN VFW

105 E HERON- Aberdeen, WA

Ann Kilwien

[sqcamper@comcast.net](mailto:sqcamper@comcast.net)

SQUARE ONE PLUS CLUB hopes that everyone is well, healthy and safe. We have certainly missed dancing and seeing everyone these past few months. As of this posting there will be no Plus dancing in Olympia the rest of 2020. Lac-A-Do Hall is not open to dancing. We are still hoping to get back out on the dance floor in the new year, but nothing is definite at this time. Please stay safe and take care of yourself and your families.

Peggy Smith,

[pegscott29@comcast.net](mailto:pegscott29@comcast.net)

THE PRAIRIE STEPPERS have survived the recent dangerous air quality due to smoke from the fires in California,

## Prairie Steppers

2nd Saturday, 7 - 8 Plus • 8 - 10:30 Mainstream

September to May, Oakview Grange,

2715 N. Pearl, Centralia, WA 98531

DON WOOD, CALLER • LONNIE SYCKS, CUER

Oregon and Washington. We hope that no further calamities will befall us for the rest of the year!

Dick and Diane Russell have hosted our November dances for the past several years. The theme has been Honor our Veterans. Dick and Diane encouraged us to display photos of our veterans in uniform at the dance so we could try to guess who they were. Travels for November were usually to the Flutterwheels student level dance so that our new dancers could get some floor time with a different caller.

In 2010 Bob and Shirley Spain hosted our November dance with a Harvest Time theme. In 2009 Don and Desda Rice hosted the November dance with the theme Old Hats and Shoes.

We miss traveling to area dances. Mike and Marion Freels have traveled to Winthrop to attend the Barn Dance for the past several years. The Freels decided to travel to Winthrop anyway this year with Chuck and Etta Gramley. While there Marion and Etta ran into several other square dancers who had also made the trip to Winthrop, dance or not.

"We can't always choose the music life plays for us, but we can choose how we dance to it."

Marion Freels

[M\\_librarion@yahoo.com](mailto:M_librarion@yahoo.com)

## SQUARE 1 PLUS

1st Friday - 7:30 - 10:00 PM

3rd Sunday - 6:30 - 9:00 PM

Gunter Monroe Caller

Guest Cuers

Lac-a-do Hall, Olympia, WA

Info: 360-754-1830

## ROUND-A-BOUTS

Lac-A-Do Hall -- Olympia

1st Tuesday & 3rd Fridays

7:30 - 9:30 PM Phase 2 & 3

Mary Parsons - Cuer & Instructor

**STARDUST DANCERS** have cancelled all the Thursday night dances in 2020. This was a hard decision but looking ahead it seemed like the best way to get back to dancing as quickly as possible.

We are hopefully looking forward to returning to dancing sometime in 2021. This has been a difficult year for everyone having to forgo favorite activities, but this isn't forever and if we do it now, we can maybe speed up the return to dancing.

Stardust round dances on the first and third Thursdays of each month when dancing resumes. Dancing begins at 7:30 p.m. and goes to 9:30 p.m. Susan Healea is our cuer/teacher.

We wish everyone a happy Thanksgiving and hope to see you in 2021.

Don and Judy Wilson  
[donjudywilson22@gmail.com](mailto:donjudywilson22@gmail.com)

**COUGAR SQUARES** are usually promoting and planning our Thankful Christmas Dance at this time. This will be the first year in many that we will not be having our biggest dance event. We will wish for good news about returning to dancing soon, but in the meantime, we will stay safe, follow social distancing, wash our hands often and stay away from large groups of people.

When we do resume dancing, we will dance on the first Saturday of each month with Jim Raupp calling and Susan Healea cueing our dances. Watch Footnotes for announcements about when dancing can resume.

We wish you a happy Thanksgiving and hope that 2021 we will see you at our Thankful Christmas Dance.

Don and Judy Wilson

**COUGAR SQUARES**  
1<sup>st</sup> Sat Sep-June  
PLUS 7:30 MS 8 - 10:30 PM  
3<sup>rd</sup> Thurs Jul (7 PM) / 1<sup>st</sup> Thurs Aug (7 PM)  
Sound Enhancement  
Caller/Cuer - JIM RAUPP  
St. Francis Rectory Hall/Spencer Rd.  
off Jackson Hwy. Toledo, WA



[donjudywilson22@gmail.com](mailto:donjudywilson22@gmail.com)

Per the guidance recently shared by the State Square and Folk Dance Federation, the **DO SI DO SQUARE DANCE CLUB** has determined it will not hold a dance through the rest of 2020. We are hopeful that 2021 will begin with an opening of the Lac A Do Hall and the re-start of our square dances.

Again, if 2021 means a return to holding our dances, we will comply with recommendations from the state organization, the Governor and State Department of Health, plus any guidance noted by OASDA for Lac A Do Hall. When we announce the reinstatement of our dances, we will also communicate impacts.

In the meantime, stay safe and healthy!

Jim Hattrick is our regular Caller and Joyce Sebree is our regular Cuer. We offer delicious treats and door prizes for those who have traveled to the dance. Join us in our monthly celebration of the Do Si Do Square Dance Club and square dancing at Lac A Do Hall (1721 46th Avenue NE, Olympia, WA 98506).

Katherine Deuel

**FLUTTERWHEELS**  
1st Saturday 7-10 pm Mainstream  
+ 3rd Saturday 7:00-9:30 pm Student Level  
**Don Wood, Caller • Marie Woods, Cuer**  
+ Glenn Raiha, Caller Guest Cuer  
Lac-A-Do Hall-1721 46th NE, Olympia, WA  
Sound Enhancement + All Dancers Welcome



# Come Dance with Sou'Wester Council Clubs

*(Note the changes of locations and days for some clubs)*

## MONDAY -

Every TANGLEFOOT CLOGGERS..... Brighton Park Grange / 4-8:00  
Mary Dart, Instructor Clogging / All levels

## TUESDAY -

1st ROUND-A-BOUTS..... Lac-A-Do Hall / 7:30-9:00  
Mary Parsons cuer ROUNDS, Phase 2-3

## THURSDAY-

1st & 3rd STARDUST DANCERS..... Catlin Grange / 7:30-9:30  
Susan Healea, cuer ROUNDS, Phase 2-4

## FRIDAY -

1st SQUARE ONE PLUS CLUB..... Lac-A-Do Hall / 7:30-10:00  
Gunter Monroe, caller; Joyce Seabee, cuer PLUS

2nd RHYTHM ROUNDERS FUN DANCE..... Lac-A-Do Hall / 7:30-10:00  
Guest cuers ROUNDS, Phase 2-5

3rd ROUND-A-BOUTS..... Lac-A-Do Hall / 7:30-9:30  
Mary Parsons, cuer ROUNDS, Phase 2-3

3rd SALTY SASHAYERS..... Shelton Senior Center / 7:00-9:00  
Tim Blacksead, caller; Guest, cuer Mainstream

4th CAPITAL SQUARES..... Lac-A-Do Hall / 7:30-10:30  
Don Wood, caller; Marie Wood, cuer SQUARES & ROUNDS

## SATURDAY -

1st COUGAR SQUARES ..... St. Francis Parish Hall / 7:30-10:30  
Jim Raupp, caller/cuer SQUARES & ROUNDS

1st FLUTTERWHEELS..... Lac-A-Do Hall / 7:00-10:00  
Guest callers and cuers SQUARES & ROUNDS

2nd OLYMPIA DO-SI-DOS..... Lac-A-Do Hall / 7:00-10:30  
Jim Hattrick, caller; Joyce Seabee, cuer SQUARES & ROUNDS

2nd PRAIRIE STEPPERS ..... Oakview Grange / 7:00-10:30  
Don Wood, cuer; Lonnie Sycks, cuer SQUARES & ROUNDS

3rd HARBOR HAYLOFTERS ..... VFW 105 E Heron / 7:00-10:00  
Randy & Chris Carlson SQUARES & ROUNDS

3rd FLUTTERWHEELS..... Lac-A-Do Hall / 7:00-10:00  
Glenn Raiha, caller; various cuers SQUARES & ROUNDS

4th SQUARE ONE PLUS ..... Lac-A-Do Hall / 7:30-10:00  
Guest Callers & Cuers PLUS

## SUNDAY -

Every DOUBLE A'S Lac-A-Do Hall / 4:30-6:30  
Jack Hardin, Caller; Lynn Petola, cuer ADVANCED

3rd SQUARE ONE PLUS CLUB..... Lac-A-Do Hall / 6:30-9:00  
Gunter Monroe, caller; Spike Reid, cuer PLUS



### ADDRESSES FOR PLACES WHERE THERE ARE MORE THAN ONE DANCE A MONTH:

Lac-A-Do Hall..... 1721 46th Ave. NE, Olympia

Catlin Grange ..... 205 Shawnee St., Kelso

St. Francis Parish Hall ..... 139 Spencer Rd., Toledo

Kelso Senior Center..... 106 NW 8th Ave., Kelso

American Legion Hall..... 112 W 1st St. Aberdeen

Oakview Grange..... 2700 N. Pearl, Centralia

# SPOKANE COUNCIL

**Area Reporter  
Priscilla Davis**

[ddavis@aol.com](mailto:ddavis@aol.com)



<https://www.squaredancespokane.org>

**S**POKANE AREA COUNCIL cancelled our general meeting that was scheduled for September 13 due to all the smoke covering Spokane. Hopefully we can have our scheduled general meeting on November 8.

The ups and down results of our Covid status continue to be with us even as we go into fall. The **COEURLY Q's** – Coeur d'Alene, ID, remain concerned about our members and future students so are keeping our club closed. As an alternative to reporting activities I am discussing with different members why they square dance and are part of a club. The following is the first interview comments from our friend Sharon.

“I have danced since 1992 and I look forward to every opportunity to be in a square. Here are my reasons I Square Dance. First, it is such a joyful activity. I've always thought and voiced that it is such happy music – always lively. It is a great fun way to get your exercise, nice people to socialize with and a bonus to wear “fancy” clothes with a sea of color and flair. While dancing, your mind is taken away from troubles and tough times you may be dealing with; you clear your mind, letting go of some of the challenges of life. There comes a natural energy boost, a way to expend energy. See you on the dance floor soon – I hope. I miss those smiles, laughing eyes and hugs. **NO DANCES ARE SCHEDULED FOR THE COEURLY Q'S** . Even though we may not see each other, we find that we're still connected with our common interest and friendship.

*Donna Seil*

**VALLEY CROSS TRAILERS** are still looking forward to starting dancing again—hopefully in January. Since we haven't seen each other and really not much contact since October reporting, there is no up-to-date news from us. Birthday greetings do go out to club members Christi (14), Howard (15) and Bob (16). And November 2 is Doug & Priscilla's 45th Anniversary. Just keep safe and well. Happy Thanksgiving to all our dancing friends.

*Priscilla Davis*

October's garage sale for Wild Rose Ramblers was cancelled due to COVID restrictions; it is now scheduled for spring – hopefully by May the virus has slowed down and mostly cleared out by then. (We keep getting wonderful items for that eventuality.)

In October, the ladies met at Sylvia Miller's home for lunch, visiting, etc. Rob Krum is getting commitments from a “few” dancers for Tuesday evenings. Our dancers are really missing the social, music and dance activity. A couple of other callers in Spokane Council are also offering private, small-group dancing. We all look forward to the time when we can dance in small, medium and/or large groups - **MISSING** our activity!! I'm sure every dancer agrees.

*Judy Ottoson*



## **Twin City Twirlers**

1st & 3rd Saturdays, Oct thru May  
Rounds: 7:30pm, Squares: 8:00pm

### **Lessons**

Thursdays, Oct thru Apr, 6:30-8:00pm  
(509) 758-3543 [www.twincitytwirlers.com](http://www.twincitytwirlers.com)  
2130 5th Ave, Clarkston (Heights), WA



**When you are in Spokane  
come & visit  
your Heritage Center**

**To schedule a visit, please contact:**

Karen Reichardt	509-329-8825
Bev Mustard	509-710-3787
Ellen Ostrum/Doug Keyes	425-308-9559



# Spokane Council Clubs Dance Schedules

Come and Dance with our Clubs

[www.squaredancespokane.org](http://www.squaredancespokane.org)



<p><b>Coeurly Q's</b> - 1<sup>st</sup> Saturday 7:00 Plus &amp; Rounds; 8:00 Mainstream &amp; Rounds Harding Family Center 411 N 15<sup>th</sup> St., Coeur d'Alene, ID 83814</p>	<p><b>Roundup Workshop</b> - Tuesdays 7:30 Rounds III-VI Western Dance Center 1901 N. Sullivan Rd, Spokane, WA 99216</p>
<p><b>Dancing Shadows</b> - 3<sup>rd</sup> Friday 7:00 Plus &amp; Rounds; 8:00 Mainstream &amp; Rounds Western Dance Center 1901 N. Sullivan Rd, Spokane, WA 99216</p>	<p><b>Spokane Area Council</b> – March 30, 2019 at WDC Gary Shoemake, Caller – Carol Shopbell, Cuer 7:00 Plus &amp; Rounds; 8:00 Mainstream &amp; Rounds</p>
<p><b>Diamond Squares</b> - 2<sup>nd</sup> Saturday 7:00 Plus &amp; Rounds; 8:00 Mainstream &amp; Rounds Western Dance Center 1901 N. Sullivan Rd, Spokane, WA 99216</p>	<p><b>Spokane Callers &amp; Cuers</b> - 2<sup>nd</sup> Friday 8:00 Mainstream &amp; Rounds Western Dance Center 1901 N. Sullivan Rd, Spokane, WA 99216</p>
<p><b>Heartbeats</b> - Wednesdays except 5<sup>th</sup> 8:30am Beginning/Intermediate/Advanced Clogging Knechtel's Shop 211 E Ziegler Ln, Colbert, WA</p>	<p><b>Spokane Carousels</b> - 1<sup>st</sup> &amp; 3<sup>rd</sup> Saturday 7:30 R III-VI East Spokane Grange 1621 N Park Rd, Spokane Valley, WA 99212</p>
<p><b>Hi-Flyers</b> - 3<sup>rd</sup> Friday 7:00 Plus &amp; Rounds; 8:00 Mainstream &amp; Rounds Cheney City Hall 609 2<sup>nd</sup> St, Cheney, WA 99004</p>	<p><b>Star Shooters</b> - 4<sup>th</sup> Saturday 7:00 Plus &amp; Rounds; 8:00 Mainstream &amp; Rounds Western Dance Center 1901 N. Sullivan Rd, Spokane, WA 99216</p>
<p><b>Hoodoo Valley Hoedowners</b> - 3<sup>rd</sup> Saturday 7:00 Plus &amp; Rounds III; 8:00 Mainstream &amp; Rounds Various Locations Call for information: 208-946-0741 <i>Special dances during year</i></p>	<p><b>Twin City Twirlers</b> - 1<sup>st</sup> &amp; 3<sup>rd</sup> Saturday 7:30 Rounds; 8:00 Mainstream &amp; Rounds Twin City Square Dance Center 2130 5<sup>th</sup> Ave, Clarkston, WA 99403</p>
<p><b>Jacks &amp; Jennys</b> - 3<sup>rd</sup> Saturday 7:00 Plus &amp; Rounds; 8:00 Mainstream &amp; Rounds North Spokane Dance Center 7424 N Freya St, Spokane, WA 99217</p>	<p><b>Valley Cross Trailers</b> - 3<sup>rd</sup> Saturday 7:00 Plus &amp; Rounds 4<sup>th</sup> Fri 7:00 Plus &amp; Rounds; 8:00 Mainstream &amp; Rounds Western Dance Center 1901 N. Sullivan Rd, Spokane, WA 99216</p>
<p><b>Krazy 8's</b> - 1<sup>st</sup> Friday 7:00 Plus &amp; Rounds III; 8:00 Mainstream &amp; Rounds Western Dance Center 1901 N. Sullivan Rd, Spokane, WA 99216</p>	<p><b>Wag Arounds</b> 1<sup>st</sup> Sunday 7:00 Rounds II-III. WDC 2<sup>nd</sup> Friday 8:00 Rounds III-V. NSDC WDC - 1901 N. Sullivan Rd. NSDC - 7424 N Freya St.</p>
<p><b>Model T's</b> - 2<sup>nd</sup> Saturday 7:00 Plus &amp; Rounds; 8:00 Mainstream &amp; Rounds North Spokane Dance Center 7424 N Freya St, Spokane, WA 99217</p>	<p><b>Western Dance Association</b> – 11/30/18 &amp; 5/31/19 7:00 Plus &amp; Rounds; 8:00 Mainstream &amp; Rounds Western Dance Center 1901 N. Sullivan Rd, Spokane, WA 99216</p>
<p><b>North Spokane Dance Assoc</b> – March 29, 2019 Gary Shoemake, Caller – Carol Shopbell, Cuer 7:00 Plus &amp; Rounds; 8:00 Mainstream &amp; Rounds North Spokane Dance Center 7424 N Freya St, Spokane, WA 99217</p>	<p><b>Wild Rose Ramblers</b> - 1<sup>st</sup> Saturday 7 Plus &amp; Rounds III; 8:00 Mainstream &amp; Rounds North Spokane Dance Center 7424 N Freya St, Spokane, WA 99217</p>
<p><b>Octo-Plus Squares</b> - Tuesdays 7:00 Plus Workshop East Spokane Grange 1621 N Park Rd, Spokane Valley, WA 99212</p>	

For more information contact **Richard Snyder** at 509-443-0126

[www.squaredancespokane.org](http://www.squaredancespokane.org)